

Remark - Part No. (024) Seat Holder

Size 3'-6" ⇒ Cast Iron, A126 Class B

Size 8'-12" ⇒ Ductile Iron, A536 Gr. 65-45-12

425	Tear Drop Bolt	Zinc Coated Steel	A 307 Grade B	1
415	Stud Nut & Nut	Zinc Coated Steel	A 307 Grade B	1set
414	Bracket	Zinc Coated Steel		1set
409	Tear Drop	Ductile Iron	A536 Gr. 65-45-12	1
380	Key B	Stainless Steel	A 276 Type 304	2
352	O-Ring C	Rubber (Buna N)	D 2000 BK 707	2
351	O-Ring B	Rubber (Buna N)	D 2000 BK 707	2
329	Cover O-Ring	Rubber (Buna N)	D 2000 BK 807	1
324	Cover Gasket	Rubber (Buna N)	D 2000 BK 807	1
302	Cover Bolt	See Cover Bolt Chart for Material		1set
283	Arm Bolt	Zinc Coated Steel	A 307 Grade B	1
220	Snap Ring	Stainless Steel	A 276 Type 420	1
198	End Plate Bolt	Zinc Coated Steel	A 307 Grade B	2set
188	Disc Seat Bolt	Stainless Steel	A 276 Type 304	1set
172	Spring	Zinc Coated Steel	A36	1
166	Plug	Stainless Steel	A 276 Type 304	1
161	Key A	Stainless Steel	A 276 Type 304	1
159	Hinge Pin	Stainless Steel	A 276 Type 304	1
155	Arm	Ductile Iron	A 536 Gr. 65-45-12	1
153	Bolt	Zinc Coated Steel	A 307 Grade B	1
075	Bushing	Bronze	B 62	2
062	Disc Seat Ring	Rubber (Buna N)	D 2000 BK 807	1
061	Body Seat Ring	Bronze	B 62	1
057	End Plate B	Ductile Iron	A 536 Gr. 65-45-12	1
038	Stopper	Stainless Steel	A 276 Type 304	1
024	Seat Holder	See Remark		1
015	End Plate A	Bronze	B 62	1
014	Cover	Cast Iron	A 126 Class B	1
003	Disc	Ductile Iron	A 536 Gr. 65-45-12	1
001	Body	Cast Iron	A 126 Class B	1
ND.	PARTS	MATERIAL	ASTM DESIGNATION	Q'TY

MATERIAL LIST	
HYDRD SHELL	400 PSI.
HYDRD VALVE SEAT	200 PSI.
HYDRD BACK SEAT	— PSI.
AIR SEAT	— PSI.
STEAM	— PSI.
TEST PRESSURE	
WORKING PRESSURE	200 PSI.



SCALE	DR. JON COLPAN	DATE 01/18/11	REF. DWG.
N.T.S.	CHK.	APP.	E.CAL USA1349D
TITLE			
SIZE 3" TO 12" SWING CHECK VALVE AWWA C508 BRONZE BODY SEAT RING & BUNA N DISC SEAT RING WITH ONE LEVER AND SPRING			
TYPE:	9001AB1LS	DWG NO.	M90008
		REV.	5

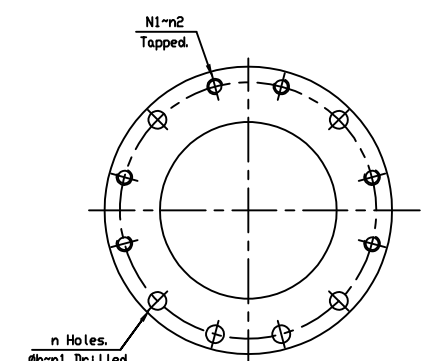
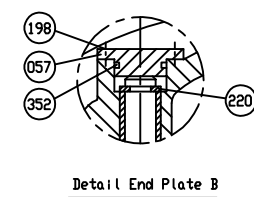
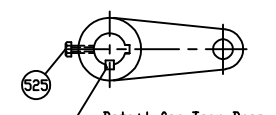
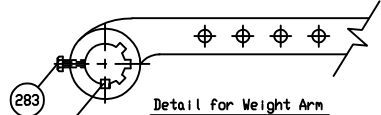
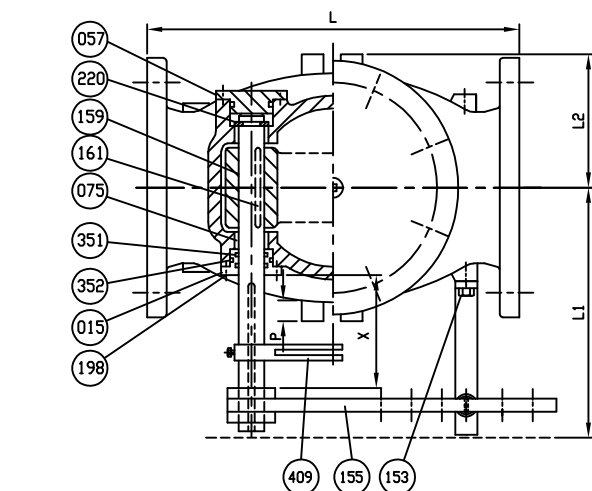

Detail of flange for size 10" (250) only.



Body Seat Screwed in

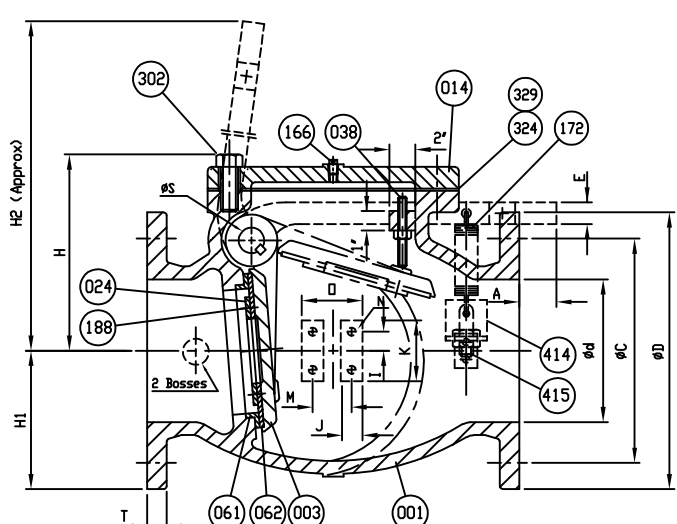

- Dimensions in inches.

SIZE ød in. mm.	L	ANSI B16.1 CL. 125					øS	E	H	H1	H2	I	J	K	M	N	N1	n1	n2	D	P	A	X	L1	L2	Plug Size
		øD	øC	øh	n	T																				
3 (80)	11	7 1/2	6	3/4	4	3/4	1	1 13/16	6 3/8	3 3/4	18	3/4	1 1/2	3	2 1/2	1/2x13v(UNC)	—	—	—	4	3/4	5	5.5	10 3/4	4	1/2
4 (100)	13	9	7 1/2	3/4	8	15/16	1 1/8	1 13/16	7 3/8	4 1/2	19 5/8	3/4	1 1/2	3	2 1/2	1/2x13v(UNC)	—	—	—	4	3/4	5	5.75	11 1/2	4 7/16	1/2
6 (150)	16	11	9 1/2	7/8	8	1	1 3/8	1 13/16	9 3/16	5 1/2	22 5/8	3/4	1 1/2	3	2 1/2	1/2x13v(UNC)	—	—	—	4	3/4	5	6	12 7/8	5 3/4	3/4
8 (200)	19 1/2	13 1/2	11 3/4	7/8	8	1 1/8	1 3/4	1 13/16	10 7/8	6 3/4	29 1/8	7/8	1 3/4	3 1/2	3 1/4	5/8x11v(UNC)	—	—	—	5	1 1/4	5.5	7	15 5/8	7 7/8	3/4
10 (250)	22	16	14 1/4	1	12	1 1/16	2 1/8	2 1/2	13 5/16	8	35	7/8	1 3/4	3 1/2	3 1/4	3/8x11v(UNC)	7/8x9v(UNC)	6	6	5	1 1/4	6.08	7.75	17 3/8	9 3/16	1
12 (300)	26	19	17	1	12	1 1/4	2 1/2	2 1/2	15 5/16	9 1/2	40 3/8	7/8	1 3/4	3 1/2	3 1/4	5/8x11v(UNC)	—	—	—	5	1 1/4	5.47	8.75	20 1/8	10 3/4	1

COVER BOLTS		
TYPE	MATERIAL	✓
STANDARD	STEEL/ZINC	
S1	304 STN. STEEL	
S3	316 STN. STEEL	

Marking
 SIZE (INCH)
 CCNE
 200 CWP
 AWWA C508
 SERIES 9000
 SCI
 YEAR
 POURING DATE

DS01 ISSUED : 240640 REVISED:-