

INSTALLATION INSTRUCTIONS  
FOR  
H-14220 AND H-14225  
END CONNECTIONS  
FOR COPPER AND STEEL TUBING

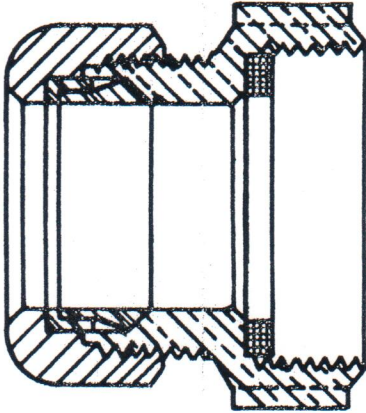

1. Clean pipe ends and remove any metal burrs, loose scale, rust or dirt that might impair the performance of the seal. Apply soapy water to the gaskets, (ethylene glycol may be added in freezing weather).
2. Loosen nut about one-quarter turn to relieve gasket pressure and stab pipe end to full entry.
3. Tighten nut - see table for wrench size. Recommended torque for these end connections is 75 lbs. pull on wrench. Tighten each nut while holding the connection body from rotating.

Recommended wrench sizes for use with the H-14220 and H-14225 end connections:

Nominal Pipe Size	Recommended Wrench Size
1/2"	14"
3/4"	14"
1"	18"

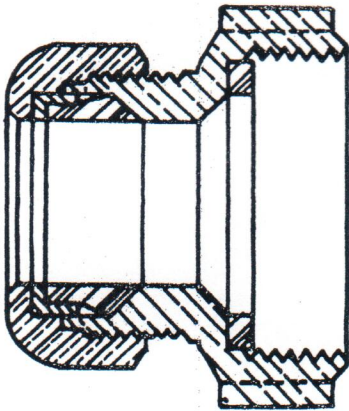

NOTICE: H-14220 AND H-14225 END CONNECTIONS ARE RESTRICTED TO USE ON METAL PIPE ONLY. THESE END CONNECTIONS ARE DESIGNED AND RECOMMENDED TO PROVIDE ONLY A SEAL IN A PIPE JOINT. THERE IS NOT PROVISION IN DESIGN OR MANUFACTURING OF THESE END CONNECTIONS TO RESIST LONGITUDINAL PULLOUT FORCES OR THRUST FORCES. THE END USER IS RESPONSIBLE FOR PROVIDING ADEQUATE TUBING ANCHORAGE WHERE PIPE MOVEMENT OUT OF THE END CONNECTIONS MIGHT OCCUR.

FOR RECOMMENDATION AS TO USE ON OTHER THAN COPPER OR STEEL, CONSULT MUELLER CO.