

No.	DESCRIPTION	MATERIAL DESCRIPTION
1	BODY	CAST LOW LEAD BRASS ALLOY
2	CAP	CAST BRASS ASTM B62 ALLOY C83600
3	STEM	LOW LEAD BRASS ALLOY
4	BALL	LOW LEAD BRASS ALLOY
5	GASKET	ASTM D2000 (NITRILE)
6	SOLID PIN	AISI 303 STAINLESS STEEL
7	O-RING	ASTM D2000 (EP)
8	END PIECE	CAST LOW LEAD BRASS ALLOY
9	O-RING	ASTM D2000 (EP)
10	CTS GASKET SUB	ASTM D2000(SBR)&410 STAINLESS STEEL
11	CONN NUT	CAST BRASS ASTM B62 ALLOY C83600

SIZE	ØA	B	C	D	E
3/4"R	.63	3.21	.75	2.12	2.87
3/4"	.75	3.36	.84	2.43	3.27
3/4x1	.75	3.59	.84	2.43	3.27
1"R	.75	3.77	.84	2.43	3.27
1"	1.00	4.52	1.15	2.57	3.72
1x3/4R	.75	3.54	.84	2.43	3.27
1-1/2"	1.50	4.69	1.50	3.37	4.87
2"	2.00	5.22	1.82	3.92	5.74

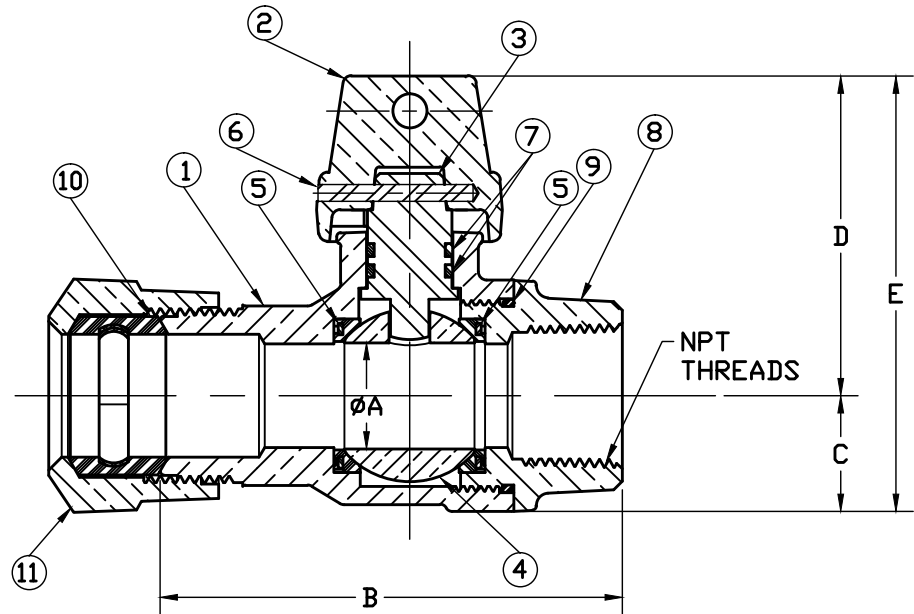

NOTE: ALL WETTED PARTS ARE LOW LEAD BRASS ALLOY

FILEPATH: PROD-ENG/MUELLER/ASYSUBMITTALS/B25172N

						DRF TR J Garvin	12/21/09	Mueller Co.					
						CHKR				UNLESS OTHERWISE NOTED THIRD ANGLE PROJECTION SURFACE PREPARATION: BREAK CORNER(S) ---- .000 SURFACE FINISH --XX RMS TOLERANCE(S): LINEAR ----- ± .000 ANGULAR ----- ± 0°00'			
						ENGR						REF. No.	SCALE FULL
						MGR							
						BY	DATE						
						STK No:							
						MAT'L:							
REV	ECR	DESCRIPTION	DATE	BY	CHKR	DESCR.			PART NUMBER				
						INLINE BALL CURB VALVE LOW LEAD BRASS (110CTS x FIP)			B25172N				
PER EST NO: X-XXXX EST FIN WT = 0.0000 lbs													

PART NUMBER
B25172N
442-MRKTG