

No.	DESCRIPTION	MATERIAL DESCRIPTION
1	BODY	CAST LOW LEAD BRASS ALLOY
2	CTS GASKET SUB	ASTM D2000(SBR)&410 STAINLESS STEEL
3	CONN NUT	CAST BRASS ASTM B62 ALLOY C83600

SIZE	A	B	C
3/4x3/4x3/4"	1.594	3.188	1.594
3/4x3/4x1"	1.852	3.704	2.000
1x1x1"	2.060	4.120	2.060
1x3/4x3/4"	1.984	3.969	1.938
1x1x3/4"	1.703	3.406	1.538
1-1/2x1-1/2x1-1/2"	1.532	3.064	2.125
1-1/2x1-1/2x3/4"	1.883	3.766	1.795
1-1/2x1-1/2x1"	1.883	3.766	1.961
2x2x2"	2.500	5.000	2.500
2x2x3/4"	2.062	4.125	2.334
2x2x1"	2.062	2.062	2.500

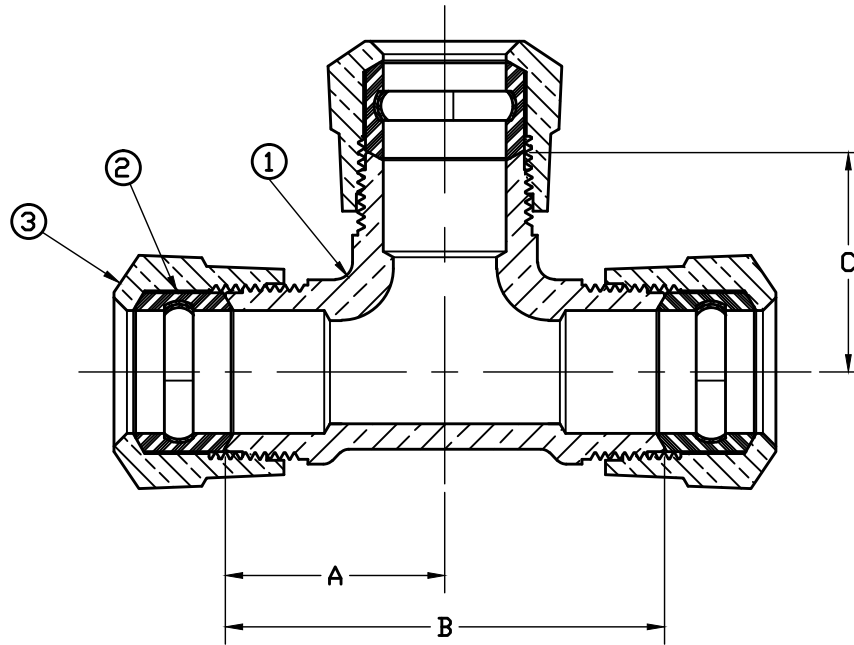

NOTE: ALL WETTED PARTS ARE LOW LEAD BRASS ALLOY

FILEPATH: PRODD-ENG\MUELLER\ASYSUBMITTALS\H15381N

				DRF TR JGarvin 12-21-09	Mueller Co.		UNLESS OTHERWISE NOTED SURFACE PREPARATION: BREAK CORNER(S) ---- .000 SURFACE FINISH -- XX RMS TOLERANCE(S): LINEAR ----- ± .000 ANGULAR ----- ± 0°00'		THIRD ANGLE PROJECTION 			
				CHKR							REF. No.	SCALE
				ENGR								
				MGR								
				BY	DATE							
				STK No:								
				MAT'L:								
REV	ECR	DESCRIPTION	DATE	BY	CHKR	DESCR.		PART NUMBER				
						BRASS TEE LOW LEAD BRASS (110 CTS × 110 CTS × 110 CTS)		H15381N				
PER EST NO: DXXXX EST FIN WT = 0.0000 lbs												

PART NUMBER
H15381N
 44E-MRKTG