

No.	DESCRIPTION	MATERIAL
1	STEM	LOW LEAD BRASS ALLOY
2	O-RING	EPDM D2000
3	BALL	LOW LEAD BRASS ALLOY
4	GASKET - SEAL	NITRILE D2000
5	BODY	CAST LOW LEAD BRASS ALLOY
6	O-RING	EPDM D2000
7	END PIECE	CAST LOW LEAD BRASS ALLOY

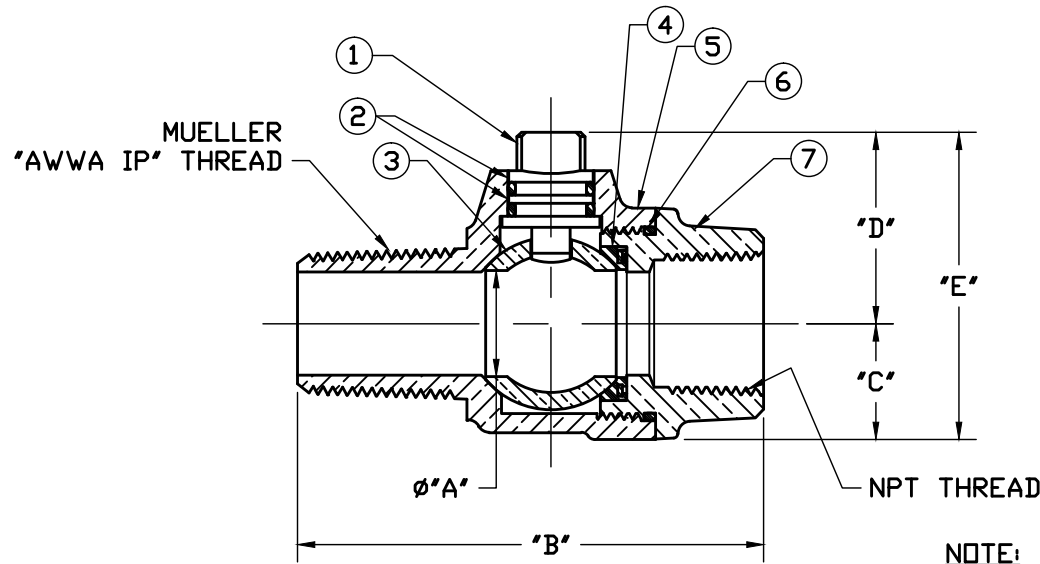

SIZE	øA	B	C	D	E
3/4	.75	3.38	.84	1.36	2.20
3/4x1	.75	3.62	.84	1.39	2.23
1	1.00	4.11	1.15	1.56	2.71
1-1/2	1.50	4.78	1.50	2.12	3.62
2	2.00	5.33	1.82	2.44	4.26

NOTE: ALL WETTED PARTS ARE LOW LEAD BRASS ALLOY

FILEPATH: PROD-ENG\MUELLER\ASYSUBMITTALS\B20046N

						DRFTR JGarvin	1/28/10	Mueller Co.		
						CHKR				
						ENGR				
						MGR				
						BY	DATE	UNLESS OTHERWISE NOTED	THIRD ANGLE PROJECTION	
								SURFACE PREPARATION:		
								BREAK CORNER(S) ---- .000		
								SURFACE FINISH -- XX RMS	REF. No.	SCALE
								TOLERANCE(S):		NONE
								LINEAR ----- ± .000		
								ANGULAR ----- ± 0°00'		
						STK No:		MATERIAL:		
						DESCR.	BALL CORPORATION VALVE		PART NUMBER	
							LOW LEAD BRASS("AWWA IP" x FIP)		B20046N	
						PER EST NO: DXXXX	EST FIN WT = 0.0000 lbs			

PART NUMBER
B20046N
442-MRKTNG