

| No. | DESCRIPTION | MATERIAL DESCRIPTION |
|-----|----------------|-------------------------------------|
| 1 | BODY | CAST LOW LEAD BRASS ALLOY |
| 2 | CAP | CAST BRASS ASTM B62 ALLOY C83600 |
| 3 | STEM | LOW LEAD BRASS ALLOY |
| 4 | BALL | LOW LEAD BRASS ALLOY |
| 5 | GASKET | ASTM D2000 (NITRILE) |
| 6 | SOLID PIN | AISI 303 STAINLESS STEEL |
| 7 | O-RING | ASTM D2000 (EP) |
| 8 | END PIECE | CAST LOW LEAD BRASS ALLOY |
| 9 | O-RING | ASTM D2000 (EP) |
| 10 | CTS GASKET SUB | ASTM D2000(SBR)&410 STAINLESS STEEL |
| 11 | CONN NUT | CAST BRASS ASTM B62 ALLOY C83600 |

| SIZE | ØA | B | C | D | E |
|------|------|------|------|------|------|
| 3/4" | .75 | 3.52 | .84 | 2.32 | 3.16 |
| 1" | 1.00 | 4.28 | 1.15 | 2.48 | 3.63 |

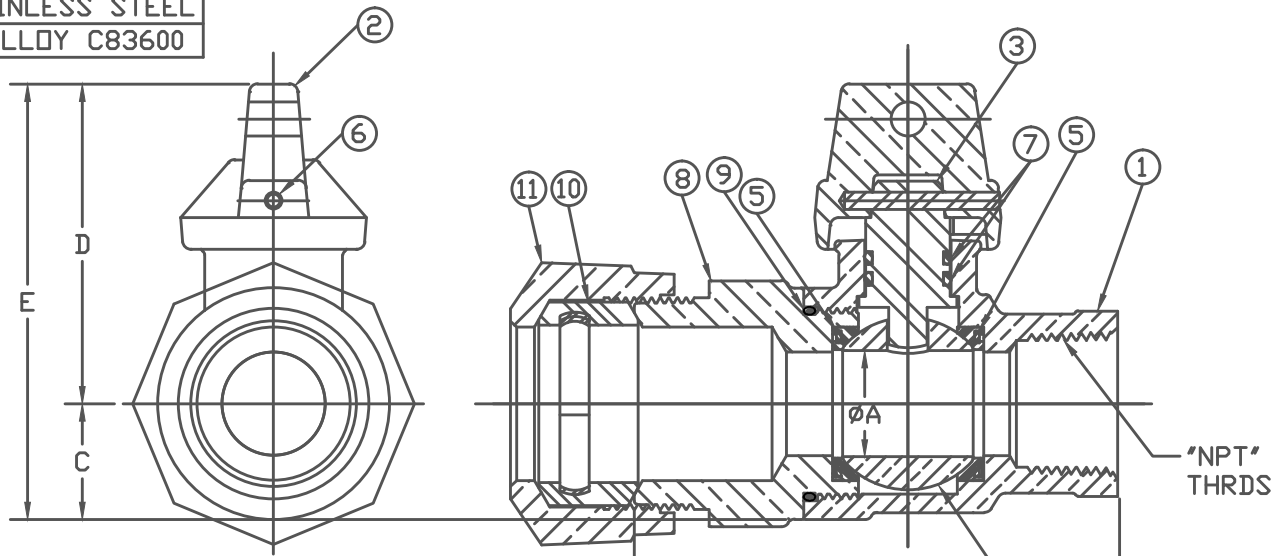

NOTE: ALL WETTED PARTS ARE LOW LEAD BRASS ALLOY

FILEPATH: PROD-ENG\MUELLER\ASYSUBMITTALS\B25171N

PART NUMBER
B25171N
442-MRKTG

| | | | |
|------------------------|--------|--|-------------------------|
| DRFTR JGarvin 12/12/11 | | Mueller Co. | |
| CHKR | | | |
| ENGR | | UNLESS OTHERWISE NOTED SURFACE PREPARATION: BREAK CORNER(S) ---- .000 SURFACE FINISH --XXX RMS TOLERANCE(S): LINEAR ----- ± .000 ANGULAR ----- ± 0°00' | THIRD ANGLE PROJECTION |
| MGR | | | REF. No. |
| BY | DATE | | FULL |
| STK No | | PART NUMBER | |
| MAT'L | | B25171N | |
| DESCR. | DESCR. | | |
| REV | ECR | DESCRIPTION | DATE |
| PER | EST | NO: X-XXXX | EST FIN WT = 0.0000 lbs |
| | | DESCR. INLINE BALL CURB VALVE - LLB 110 IPS x FIP CONNX ASSEMBLY | |