

A - CLOSED
AA - OPEN

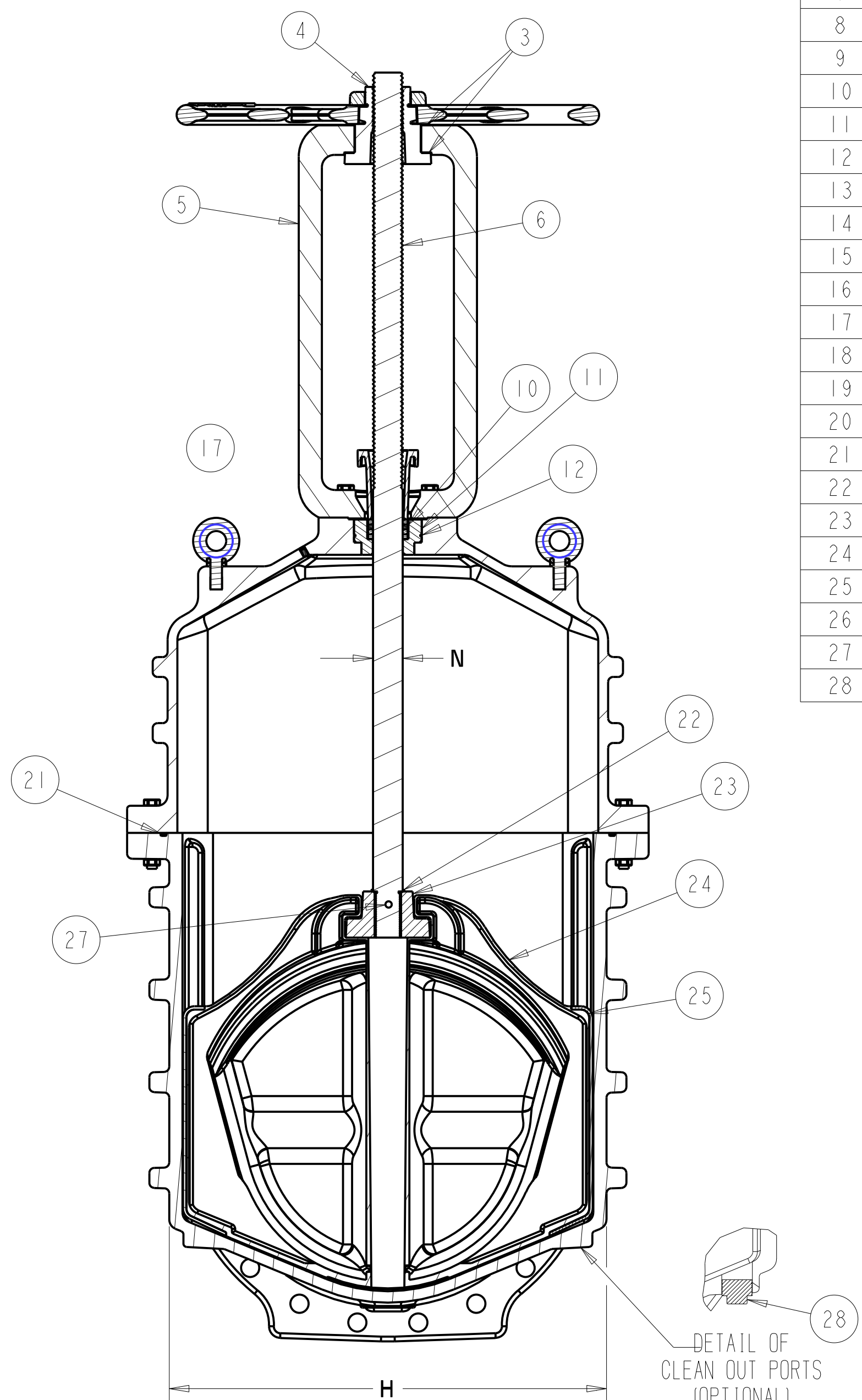

SECTION A-A

PARTS LIST					
ITEM	DESCRIPTION	REQ'D	MATERIAL	ASTM	REMARKS
1	CAP NUT	1	BRONZE	B62	ALLOY C83600
2	HANDWHEEL	1	DUCTILE IRON	A536	GRADE 65-45-12
3	THRUST WASHER	2	BRASS (A)		
4	BUSH NUT	1	BRONZE	B584 (A)	ALLOY C83600
5	YOKE	1	DUCTILE IRON	A536	GRADE 65-45-12
6	STEM	1	BRONZE	B138	ALLOY 67600 HO2 (A)
7	GLAND FLANGE	1	DUCTILE IRON	A536	GRADE 65-45-12
8	GLAND BOLT	2	SEE NOTE 2		
9	GLAND NUT	2	SILICON BRONZE	B98	ALLOY B-12
10	STEM PACKING	4	LUBE FLAX		FED HH-P-106c
11	BONNET BUSHING	1	BRONZE	B62	ALLOY C83600
12	BUSHING O-RING	1	RUBBER	D2000	R73 (EPDM) (A)
13	YOKE BOLT	4	SEE NOTE 2		
14	YOKE NUT	4	SEE NOTE 2		
15	EYEBOLT	2	STEEL		GALVANIZED
16	EYEBOLT NUT	2	SEE NOTE 2		
17	PIPE PLUG	1	304 S. STEEL	A193	GRADE B8
18	BONNET	1	DUCTILE IRON	A536	GRADE 65-45-12
19	BONNET BOLT	"M"	SEE NOTE 2		
20	BONNET NUT	"M"	SEE NOTE 2		
21	BONNET O-RING	1	RUBBER	D2000	R73 (EPDM) (A)
22	STEM O-RING	1	RUBBER	D2000	R73 (EPDM) (A)
23	DISC NUT	1	BRONZE	B62	ALLOY C83600
24	DISC	1	SEE NOTE 1		
25	GUIDE CAP	2	CELCON		M90
26	BODY	1	DUCTILE IRON	A536	GRADE 65-45-12
27	PIN	1	304 S. STEEL (A)		
28	PIPE PLUG	2	SUPPLIED WHEN TAPPED		

NOTE:
 1) RUBBER ENCAPSULATED DUCTILE IRON DISC
 RUBBER - EPDM ASTM D2000
 DUCTILE IRON ASTM A536 GRADE 65-45-12
 2) BOLTS - SAE J429 GRADE 2
 NUTS - ASTM A563 GRADE A (A)
 FASTENERS - PLATED TO ASTM F1941 CLASS Fe/Zn 12C

K - NO. & SIZE OF HOLES
 L - DIA. OF BOLT CIRCLE
 STRADDLE

DIMENSIONS FOR RWGV OS&Y - INCHES

VALVE SIZE	A	AA	B	C	D	E	F	G	H	K	L	M	N	URNS TO OPEN
18	65.88	85.68	17.00	30.50	32.00	18.38	25.00	1.66	25.13	16 - 1.25	22.75	12	1.88	57
20	71.50	93.50	18.00	33.75	32.00	20.38	27.50	1.78	28.25	20 - 1.25	25.00	12	2.00	63
24	79.89	104.40	20.00	39.50	32.00	24.38	32.00	2.00	33.13	20 - 1.38	29.50	16	2.25	75

ECO 154412
 A ECO 1589321
 BRASS WAS BRONZE
 B584 WAS B62
 ADDED HO2, ADDED R73
 304 WAS 303, A WAS B
 JAB 04/05/12

APPROVED
 By Charles Graham Hines at 9:59 am, Apr 06, 2012

DR BY: NAF	8/26/10	UNLESS OTHERWISE NOTED	THIRD ANGLE PROJECTION	C.D. NO.						
CHKD: CGH	8/26/10	BREAK CAST CORNERS!	<table border="1"> <tr> <td>PURCH: NO</td> <td>FINISH: ASSY</td> <td>PART: NO.</td> </tr> <tr> <td>REF. NO.</td> <td>SCALE: NONE</td> <td></td> </tr> </table>	PURCH: NO	FINISH: ASSY	PART: NO.	REF. NO.	SCALE: NONE		
PURCH: NO	FINISH: ASSY	PART: NO.								
REF. NO.	SCALE: NONE									
ENGR: RWV	8/26/10	BREAK MACH CORNERS!								
MFR:		TOLERANCES								
MFG:		UNLESS OTHERWISE NOTED								
TOOL:		LINEAR	ANGULAR							
FDRT:		±	±							

MAT'L: NOTED	DESCR: 18" - 24" RWGV OS&Y	NUMBER: 6843
--------------	----------------------------	--------------

6843 18" - 24" RWGV OS&Y