

No.	DESCRIPTION	MATERIAL
1	CAP	CAST BRASS ASTM B62 ALLOY C83600
2	SOLID PIN	BRASS ASTM B16 ALLOY C36000
3	STEM	CAST LOW LEAD BRASS ALLOY
4	O-RING	EPDM ASTM D2000
5	BODY	CAST LOW LEAD BRASS ALLOY
6	SADDLE NUT	CAST BRASS ASTM B62 ALLOY C83600
7	SNAP RING	PHOS BRONZE
8	RUBBER GASKET	NITRILE ASTM D2000
9	COMP GASKET	BUNA N ASTM D2000
10	WASHER	POLYPROPYLENE
11	CLPG NUT SUB	CAST BRASS ASTM B62 ALLOY C83600

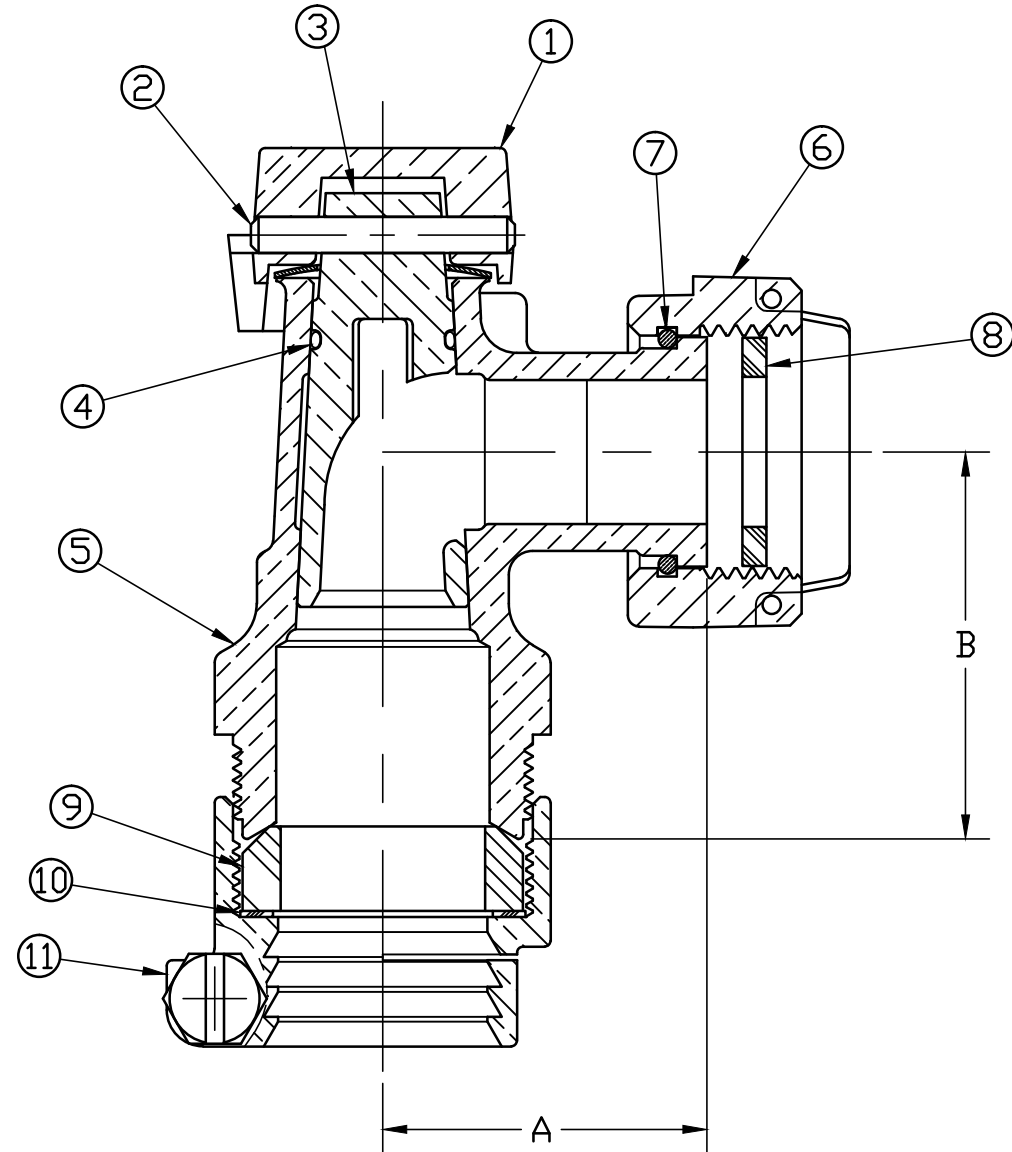

SIZE	A	B
5/8 x 3/4 x 3/4	1.69	2.02
1	1.94	2.03

ALL WETTED PARTS ARE LOW LEAD BRASS ALLOY

FILEPATH: PROD-ENG\MUELLER\ASTSUBMITTALS\E14259N

DRFTR	RWB	5/2/13	<b>Mueller Co.</b>		
CHKR					
ENGR					
MGR					
			UNLESS OTHERWISE NOTED	THIRD ANGLE PROJECTION	
			SURFACE PREPARATION:		
			BREAK CORNER(S) ----- .000		
			SURFACE FINISH -- XX RMS	REF. No.	
			TOLERANCE(S):	SCALE	
			LINEAR ----- ± .000	NONE	
			ANGULAR ----- ± 0°00'		
			STK No:		
			MAT'L:		
			DESCR.	ANGLE METER LLB VALVE (PEP PJ x MTR)	
				DWG NUMBER E14259N	
REV	ECR	DESCRIPTION	DATE	BY	CHKR
PER EST NO: DXXXX EST FIN WT = 0.0000 lbs					

DWG NUMBER  
 E14259N  
 442-MRKTG

TITLE TO AND OWNERSHIP OF THIS ENGINEERING  
 DATA REMAINS IN Mueller Co. NO USE IS TO BE  
 MADE OF THIS DATA EXCEPT AS SPECIFICALLY  
 AUTHORIZED BY Mueller Co. ASSENT ON THE PART  
 OF THE RECIPIENT TO THESE CONDITIONS IS PRESUMED