

No.	DESCRIPTION	REQ'D	MATERIAL	ASTM	ALLOY OR TYPE
1	SPUD	1	CAST LOW LEAD BRASS ALLOY		
2	O-RING	1	RUBBER	D-2000	NITRILE
3	INS. TAILPC ASS'Y	1	LOW LEAD BRASS ALLOY W/ NYLON		
4	COUP. NUT	1	BRASS	B-62	ALLOY C83600
5	CTS GSKT ASSY	1	RUBBER	D-2000	SBR
6	CONN NUT	1	BRASS	B-62	ALLOY C83600

SIZE	ϕA	B
3/4"	.750	3.893
1"	1.000	4.222

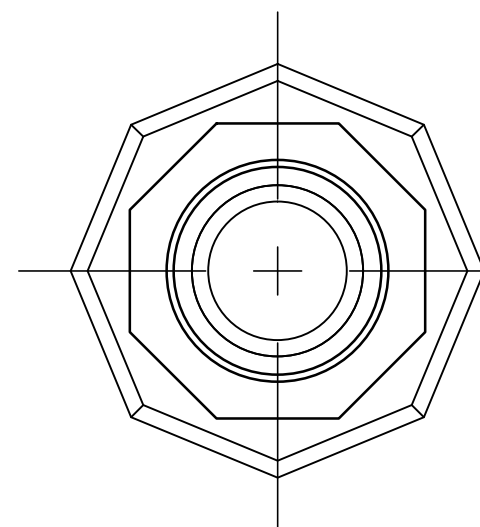
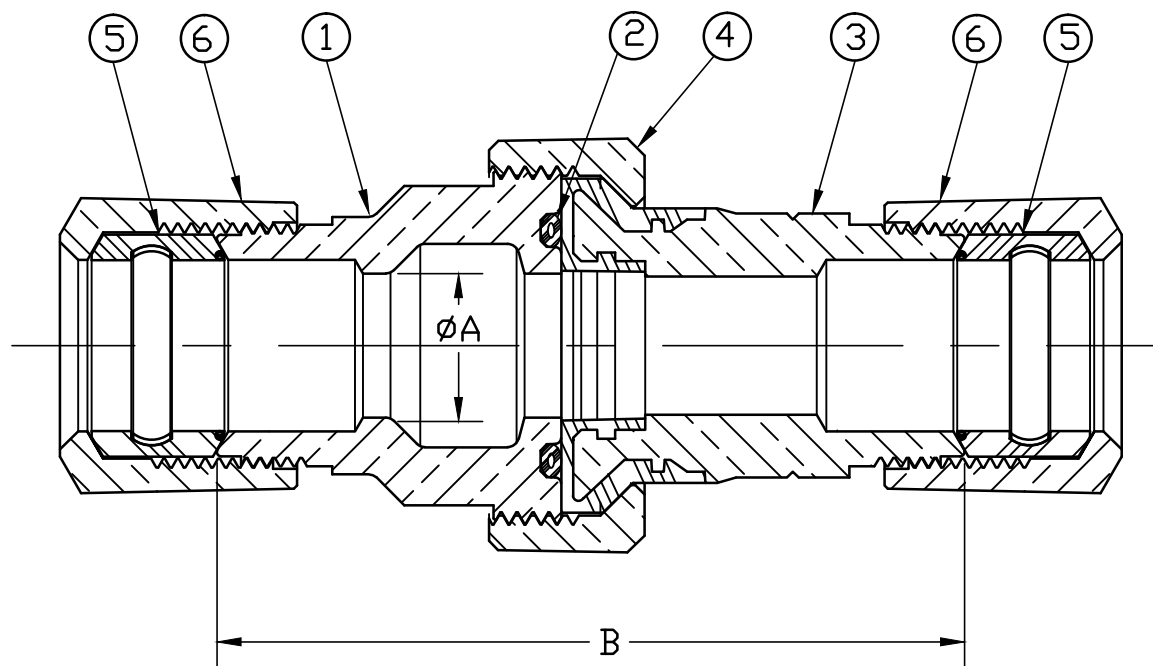

FILEPATH: PROD-ENG\MUELLER\APPROVED\N35403N

						DRFTR	RWB	10/18/13
						CHKR		
						ENGR		
						MGR		
							BY	DATE
						STK No:		
						MAT'L:		
						DESCR.		
						SERVICE FITTING LLB ASS'Y		
						110 "CTS" x INSULATED UNION		
						PER EST NO: XXXXX EST FIN WT = 0.0000 lbs		

Mueller Co.

UNLESS OTHERWISE NOTED
 SURFACE PREPARATION:
 BREAK CORNER(S) ---- .000
 SURFACE FINISH -- 000 RMS
 TOLERANCE(S):
 LINEAR ----- ± .000
 ANGULAR ----- ± 0°00'

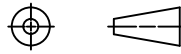
THIRD ANGLE PROJECTION

 REF. No. SCALE
 FULL

TITLE TO AND OWNERSHIP OF THIS ENGINEERING
 DATA REMAINS IN Mueller Co. NO USE IS TO BE
 MADE OF THIS DATA EXCEPT AS SPECIFICALLY
 AUTHORIZED BY Mueller Co. ASSENT ON THE PART
 OF THE RECIPIENT TO THESE CONDITIONS IS PRESUMED

WAS EXP NO:

DWG NUMBER
 N35403N

44²-MRKTNG

DWG NUMBER
 N35403N