

No.	DESCRIPTION	DESCRIPTION
1	BODY	CAST LOW LEAD BRASS ALLOY
2	KEY	CAST LOW LEAD BRASS ALLOY
3	O-RING	EPDM D2000
4	O-RING	EP D2000
5	O-RING	EPDM D2000
6	RETAINING RING	BERYLLIUM COPEER ASTM B197

SIZE	ØA	B	C	D	KEY HEAD
1-1/2"	1.50	5.86	2.32	4.25	.56 x 1.50
2"	1.94	6.81	2.47	4.58	.62 x 1.75

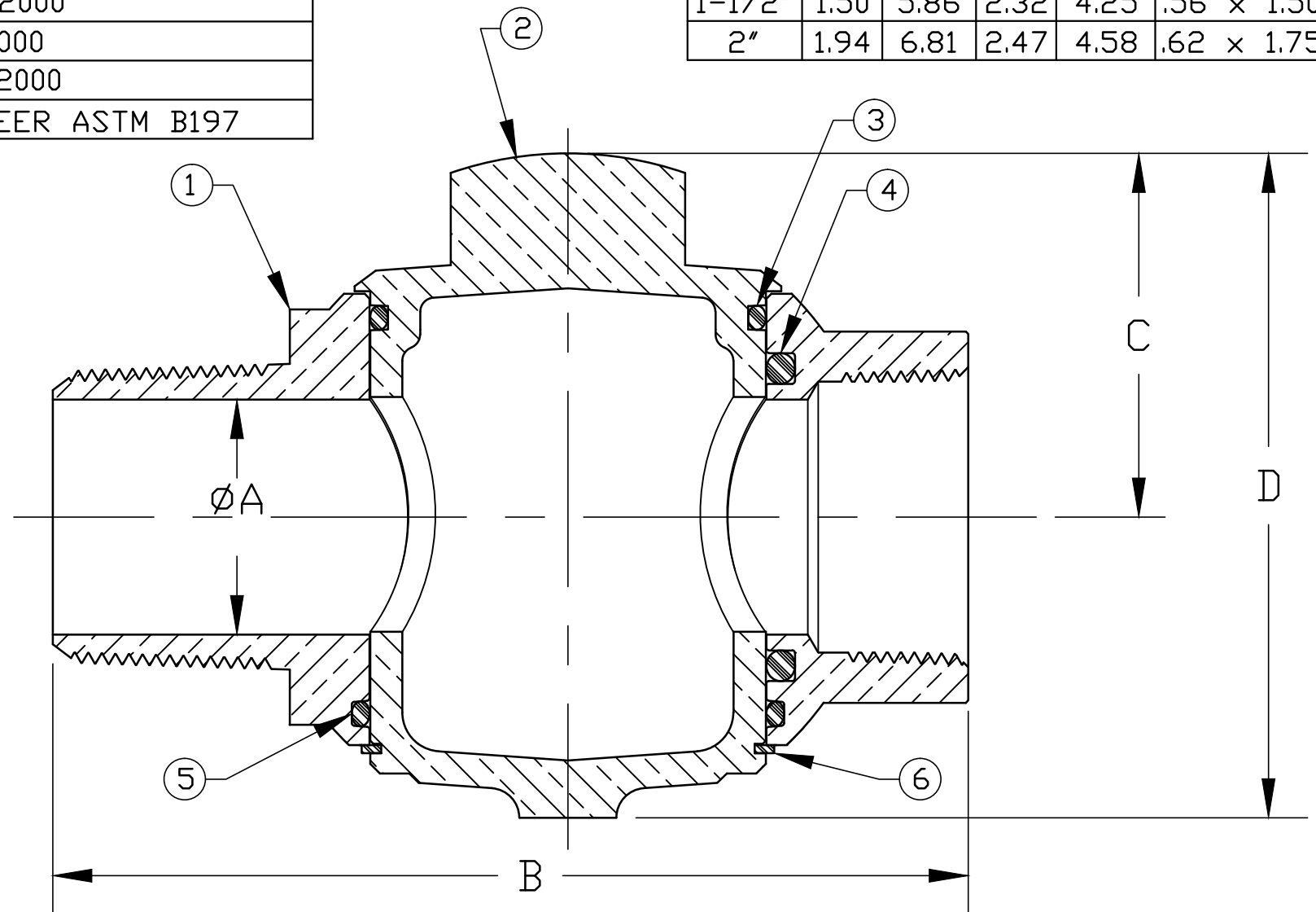

NOTE: ALL WETTED PARTS ARE LOW LEAD BRASS ALLOY

FILEPATH: PROD-ENG\MUELLER\ASYSUBMITTALS\H15015N

DRFTR	RWB	9/12/14	Mueller Co.	
CHKR				
ENGR				
MGR				
			UNLESS OTHERWISE NOTED	THIRD ANGLE PROJECTION
			SURFACE PREPARATION:	
			BREAK CORNER(S) ---- .000	
			SURFACE FINISH -- XX RMS	REF. No.
			TOLERANCE(S):	SCALE
			LINEAR ----- ± .000	FULL
			ANGULAR ----- ± 0°00'	
			STK No:	
			MAT'L:	
			DESCR.	
			ORISEAL LLB CORPORATION VALVE (MIP x FIP)	
			DWG NUMBER H15015N	

DWG NUMBER
H15015N
442-MRKTG

TITLE TO AND OWNERSHIP OF THIS ENGINEERING DATA REMAINS IN Mueller Co. NO USE IS TO BE MADE OF THIS DATA EXCEPT AS SPECIFICALLY AUTHORIZED BY Mueller Co. ASSENT ON THE PART OF THE RECIPIENT TO THESE CONDITIONS IS PRESUMED

REV	ECR	DESCRIPTION	DATE	BY	CHKR

PER EST NO: DXXXX EST FIN WT = 0.0000 lbs