

SECTION A-A

H - No. and Size of Holes and Slots Equally Spaced on

∅J - Bolt Circle
2 MJ Ends

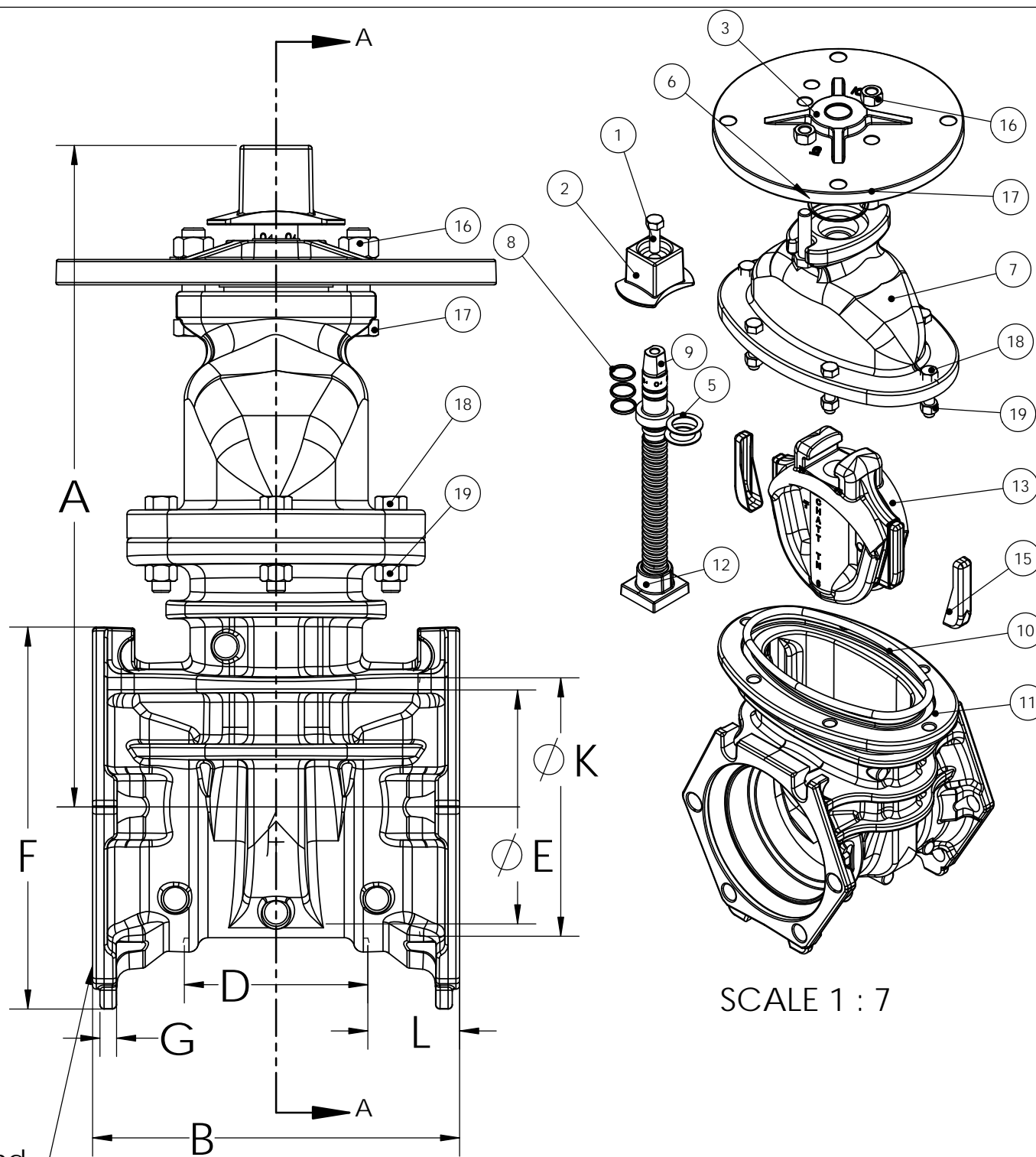

SCALE 1 : 7

ITEM NO.	DESCRIPTION	B. QTY.	MATERIAL	ASTM	NOTES
1	Cap Screw	1	304 Stainless Steel	F593	Group 1 - CW
2	Wrench Nut	1	Ductile Iron	A536	
3	PIV Stuffing Box	1	Ductile Iron	A536	
4	Wiper Ring (dirt seal)	1	Thermoplastic Polyurethane	D412/ D624 D2240/D792	HY-52D
5	Anti-friction Washer	2	Acetal		
6	Stuffing Box O-Ring	1	Nitrile Rubber		R34
7	Bonnet	1	Ductile Iron	A536	
8	Stem O-ring	3	Nitrile Rubber		R34
9	Stem	1	Bronze	‡	See Note
10	Bonnet O-ring	1	Nitrile Rubber		R34
11	Body MJ Ends	1	Ductile Iron	A536	
12	Stem Nut	1	Bronze	B584	C89833 / NSF 372
13	Encapsulated Disc	1	◆	D2000	See Note
14	Disc Casting	1	Ductile Iron	A536	
15	Guide Cap	2	Acetal		
16	Stuffing box nuts	2	304 Stainless Steel	F594	Group 1 - CW
17	Stuffing box bolts	2	304 Stainless Steel	F593	Group 1 - SH
18	Bonnet bolts	"M"	304 Stainless Steel	F593	Group 1 - SH
19	Bonnet nuts	"M"	304 Stainless Steel	F594	Group 1 - CW

◆ Rubber Encapsulated Ductile Iron Disc
Ductile Iron - ASTM A536
Rubber Options
1. SBR - ASTM D2000
2. EPDM - ASTM D2000

‡ Bronze Stem Options:
1. Manganese - ASTM B138
• Alloy C67600
2. Everdur - ASTM B98
• Alloy C66100

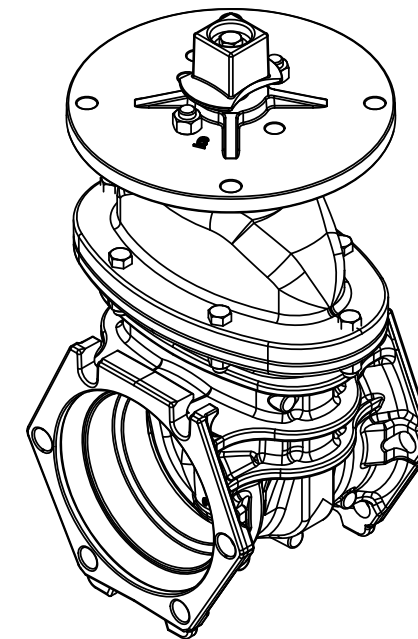

APPROVED
By Jason W. Bradley at 4:24 pm, Nov 16, 2015

Valve Size	A	B	C	D	∅E (Thru ∅)	F	G	H	∅J (Bolt Circle ∅)	∅K	L	M	Turns to Open	Weight
4	14.19	9.5	10.79	4.50	4.30	8.40	0.50	4--0.88	7.50	4.90	2.50	4	14	75
6	18.00	10	13.5	5.00	6.30	10.41	0.45	6--0.88	9.50	7.00	2.50	6	20.5	124
8	21.50	10.5	16.36	5.50	8.30	12.68	0.50	6--0.88	11.75	9.15	2.50	6	26.5	181
10	25.50	11.5	20	6.50	10.30	15.24	0.62	8--0.88	14.00	11.20	2.50	6	33	270
12	28.62	12	21	7.00	12.30	18.024	0.62	8--0.88	16.25	13.30	2.50	8	38.5	345

MUELLER CONFIDENTIAL		UNLESS OTHERWISE SPECIFIED:				NAME		DATE		DESCR. 2361 RWGV 350W W/ PIV SBX Submittal Drawing	
TITLE TO AND OWNERSHIP OF THIS ENGINEERING DATA REMAINS IN MUELLER CO. NO USE IS TO BE MADE OF THIS DATA EXCEPT AS SPECIFICALLY AUTHORIZED BY MUELLER CO. ASSENT ON THE PART OF THE RECIPIENTS TO THESE CONDITIONS IS PRESUMED.		DIMENSIONS ARE IN INCHES TOLERANCES: FRACTIONAL ± ANGULAR: MACH ± BEND ± TWO PLACE DECIMAL ± THREE PLACE DECIMAL ±				DRAWN MPS 11/11/2015		CHECKED AO 11/11/2015			
				MATERIAL						DWG. NO. 7267	
				FINISH						REV 0	
								DO NOT SCALE DRAWING		WEIGHT: SHEET 1 OF 1	