

No.	DESCRIPTION	MATERIAL
1	SPUD	CAST LOW LEAD BRASS ALLOY
2	COUPLING NUT	CAST BRASS ASTM B62 ALLOY C83600
3	TAILPIECE	CAST LOW LEAD BRASS ALLOY

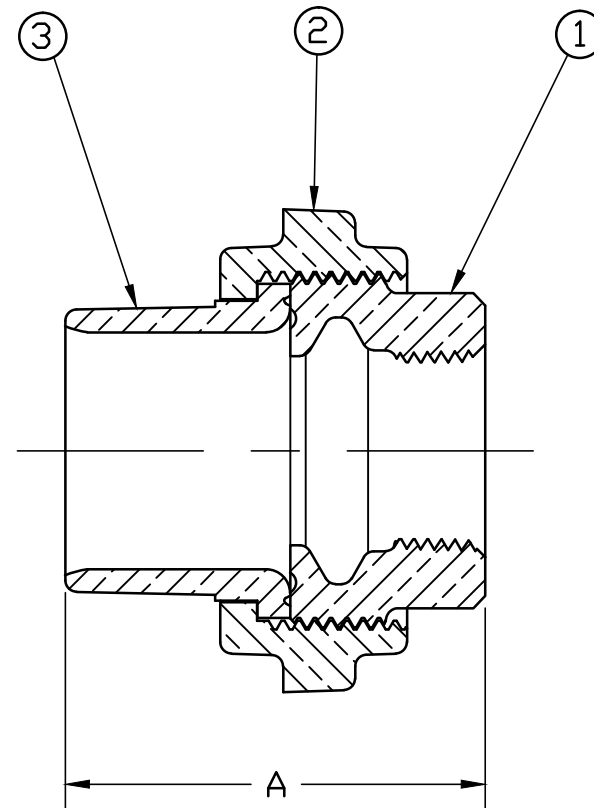

SIZE	A
1/2"	1.89
1/2" x 3/4"	1.95
5/8" x 1/2"	2.09
5/8" x 3/4"	2.14
3/4"	2.19
1"	2.33
1-1/2"	2.91

ALL WETTED PARTS ARE LOW LEAD BRASS ALLOY

FILEPATH: PROD-ENG\MUELLER\ASYSUBMITTALS\H10050N

						DRFTR	RWB	9/25/14	<b>Mueller Co.</b>	THIRD ANGLE PROJECTION 
						CHKR				
						ENGR				
						MGR				
									UNLESS OTHERWISE NOTED	
									SURFACE PREPARATION:	
									BREAK CORNER(S) ---- .000	REF. No.
									SURFACE FINISH -- XX RMS	SCALE
									TOLERANCE(S):	
									LINEAR ----- ± .000	
									ANGULAR ----- ± 0°00'	
								STK No:		
								MAT'L:		
								DESCR.		
									EXTRA STRONG LLB LEAD FLANGE x FIP	DWG NUMBER
										H10050N

TITLE TO AND OWNERSHIP OF THIS ENGINEERING DATA REMAINS IN Mueller Co. NO USE IS TO BE MADE OF THIS DATA EXCEPT AS SPECIFICALLY AUTHORIZED BY Mueller Co. ASSENT ON THE PART OF THE RECIPIENT TO THESE CONDITIONS IS PRESUMED

REV	ECR	DESCRIPTION	DATE	BY	CHKR

PER EST NO: DXXXX EST FIN WT = 0.0000 lbs

DWG NUMBER  
H10050N  
442-MRKTG