

No.	QTY.	DESCRIPTION	MATERIAL
1	1	SPUD	CAST LOW LEAD BRASS ALLOY
2	2	THAW NUT W/ SCREW	CAST BRASS ASTM B62 ALLOY C83600
3	2	CTS GSKT SUB	SBR D2000 - GSKT 410ss - BAND

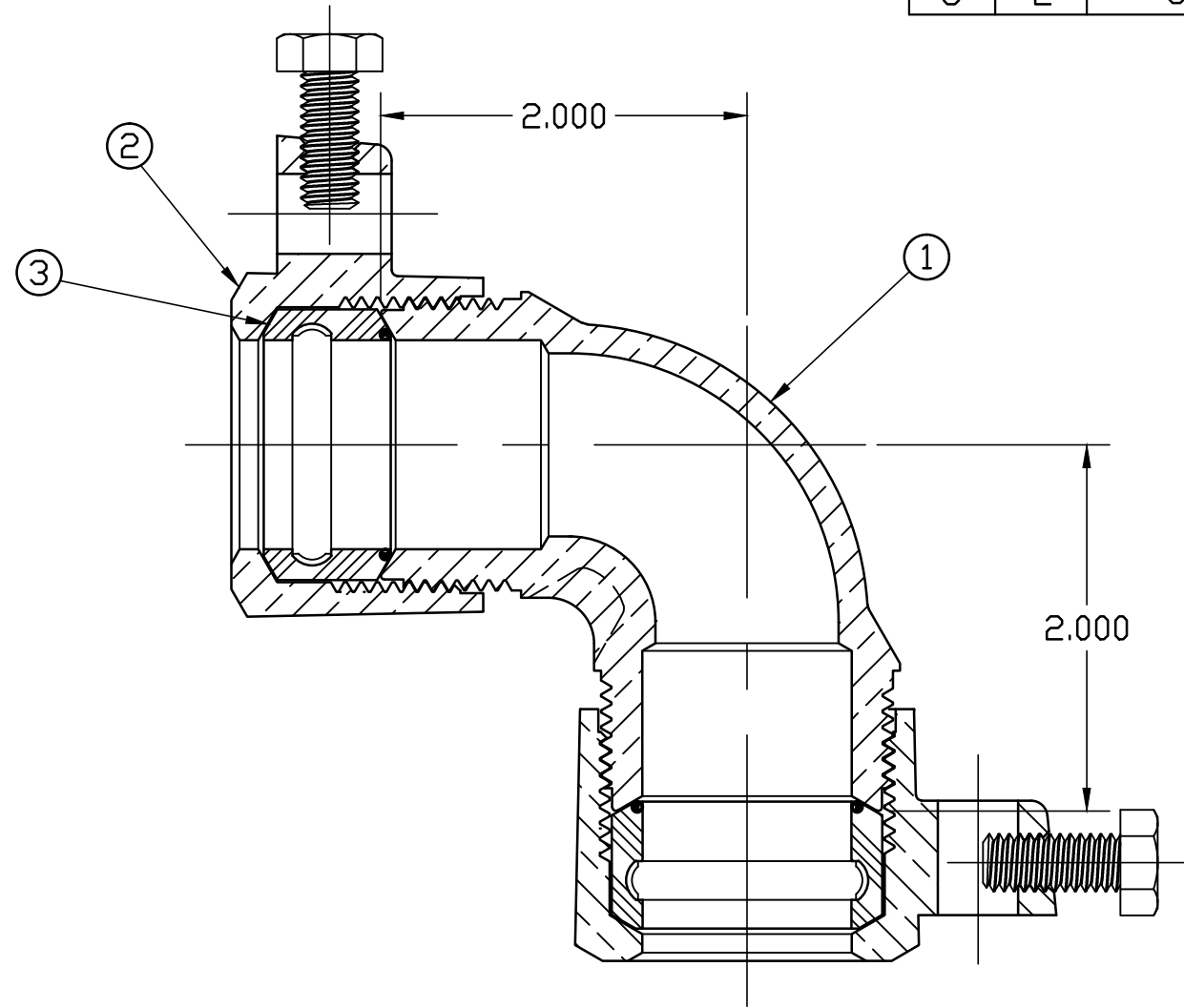

SIZE	A
1"	2.000
1-1/2"	2.750
2"	3.094

ALL WETTED PARTS ARE LOW LEAD BRASS ALLOY

FILEPATH: PROD-ENG\MUELLER\ASYSUBMITTALS\H1552607N

						DRFTR	RWB	6/7/17	Mueller Co.		
						CHKR					
						ENGR					
						MGR					
									UNLESS OTHERWISE NOTED	THIRD ANGLE PROJECTION	
									SURFACE PREPARATION:		
									BREAK CORNER(S) ----- .000		
									SURFACE FINISH -- 000 RMS	REF. No.	SCALE
									TOLERANCE(S):		NONE
									LINEAR ----- ± .000		
									ANGULAR ----- ± 0°00'		
									STK No:		
									MAT'L:		
									DESCR.	1/4 BEND LLB SERVICE FITTING (110 CTS THAW NUT ENDS)	DWG NUMBER H1552607N
									PER EST NO: DXXXX EST FIN WT = 0.0000 lbs		

DWG NUMBER
H1552607N
442-MRKTG

TITLE TO AND OWNERSHIP OF THIS ENGINEERING DATA REMAINS IN Mueller Co. NO USE IS TO BE MADE OF THIS DATA EXCEPT AS SPECIFICALLY AUTHORIZED BY Mueller Co. ASSENT ON THE PART OF THE RECIPIENT TO THESE CONDITIONS IS PRESUMED