

ITEM NO	PART NUMBER	QTY	DESCRIPTION	MATERIAL
1	047139	1	1" X 1-1/2" CLOSED NIPPLE	RED BRASS ASTM B43 ALLOY C23000 O61 TEMPER ANNEALED
2	530146	1	TEE (2" FIP X 2" SOLDER X 1" FIP)	LEAD FREE BRASS ALLOY ASTM B584 C89833/C87850
3	330B25170N	1	1" INLINE BALL VALVE (110 X FIP)	LEAD FREE BRASS ALLOY ASTM B584 C89833/C87850
4	508441E	1	2" SPUD	LEAD FREE BRASS ALLOY ASTM B584 C89833/C87850
5	550B2428601N	1	2" FULL PORT BALL VALVE	LEAD FREE BRASS ALLOY ASTM B584 C89833/C87850
6	550H14244N	1	2" DUAL CHECK VALVE	LEAD FREE BRASS ALLOY ASTM B584 C89833/C87850
7	680378E	1	RISER SUB ASSEMBLY	HARD COPPER TUBING UNS C12200 H80 TEMPER
8	681559E	1	RISER SUB ASSEMBLY	COPPER TUBING UNS C12200 H80 TEMPER
9	682188E	1	1" BYPASS SUB ASSEMBLY	TYPE K COPPER TUBING
10	790048E	1	2" x 2" x 1" FIP TEE	CAST BRONZE ASTM B584 ALLOY C89833

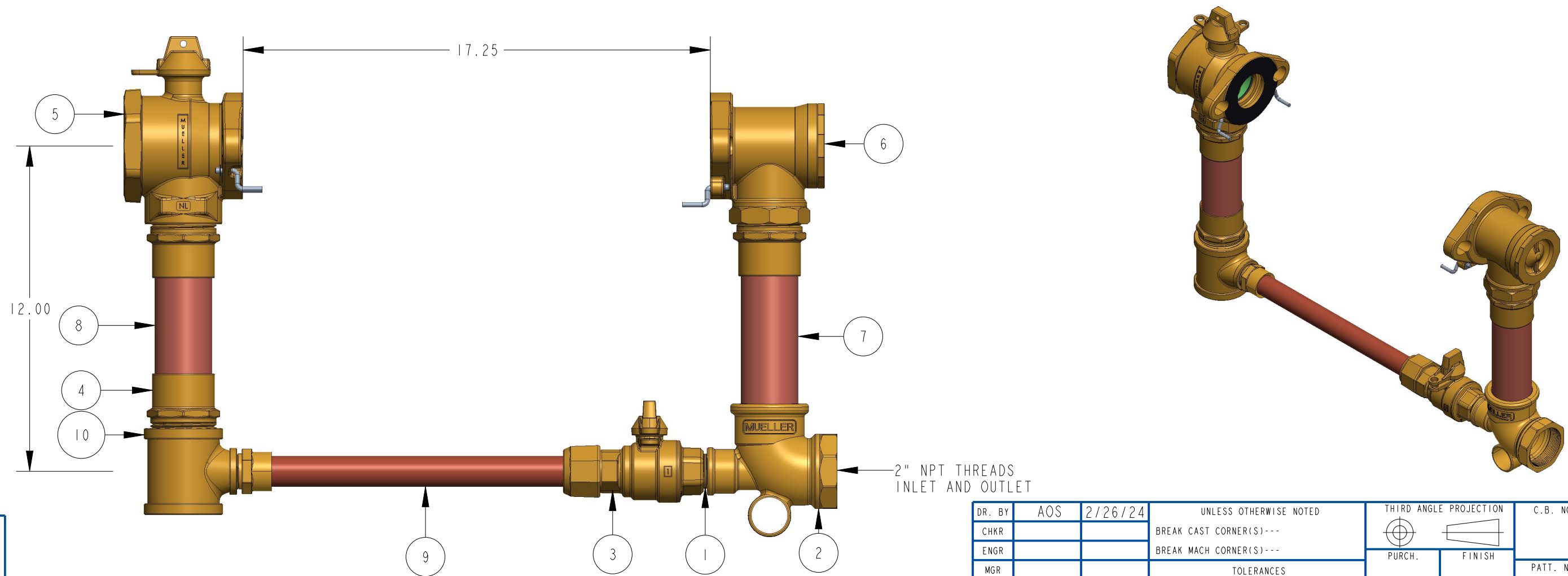

DR. BY	AOS	2/26/24	UNLESS OTHERWISE NOTED	THIRD ANGLE PROJECTION	C.B. NO.
CHKR			BREAK CAST CORNER(S)---		
ENGR			BREAK MACH CORNER(S)---	PURCH.	FINISH
MGR			TOLERANCES	REF. NO.	PATT. NO.
MFG			UNLESS OTHERWISE NOTED	SCALE	
TOOL			LINEAR	ANGULAR	
FDRY			±	±	STK. NO.
MAT'L:					
MUELLER		DESCR. 2" COPPER METER SETTER 12" RISER HEIGHT LEAD FREE BRASS	NUMBER 105B2429--2---N		

105B2429--2---N