

ITEM NO	PART NUMBER	QTY	DESCRIPTION	MATERIAL
1	311965	1	15-10 ABS PLATFORM	PLASTIC VIRGIN POLYLAC, PA747 ABS BLACK RESIN OR PROOFED EQUIVALENT RESIN
2	700013	4	3/4" HOSE CONNECTOR	RED BRASS ASTM B43 ALLOY C23000 O61 TEMPER ANNEALED
3	700035-1566	2	3/4" COIL PART	POLYBUTYLENE TUBING SDR-9
4	780001-1554	1	SHELL SUB ASSEMBLY	SDR-51 PVC PIPE ASTM D2241 GRADE 1120
5	790006	8	3/4" HEX NUT	ASTM B16 ALLOY C36000
6	790007	1	15" CAST IRON FLAT LID	CAST IRON ASTM A126 CLASS B
7	790022	1	15" INSULATION PAD (SOLD SEPARATELY)	ETHAFOAM 220 WHITE OR POLYLAM 1.7 DENSITY WHITE
8	215B2426551N	1	5/8" X 3/4" FULL PORT BALL VALVE	LEAD FREE BRASS ALLOY ASTM B584 C89833/C87850
9	215H14244	1	5/8" X3/4" DUAL CHECK VALVE	LEAD FREE BRASS ALLOY ASTM B584 C89833/C87850

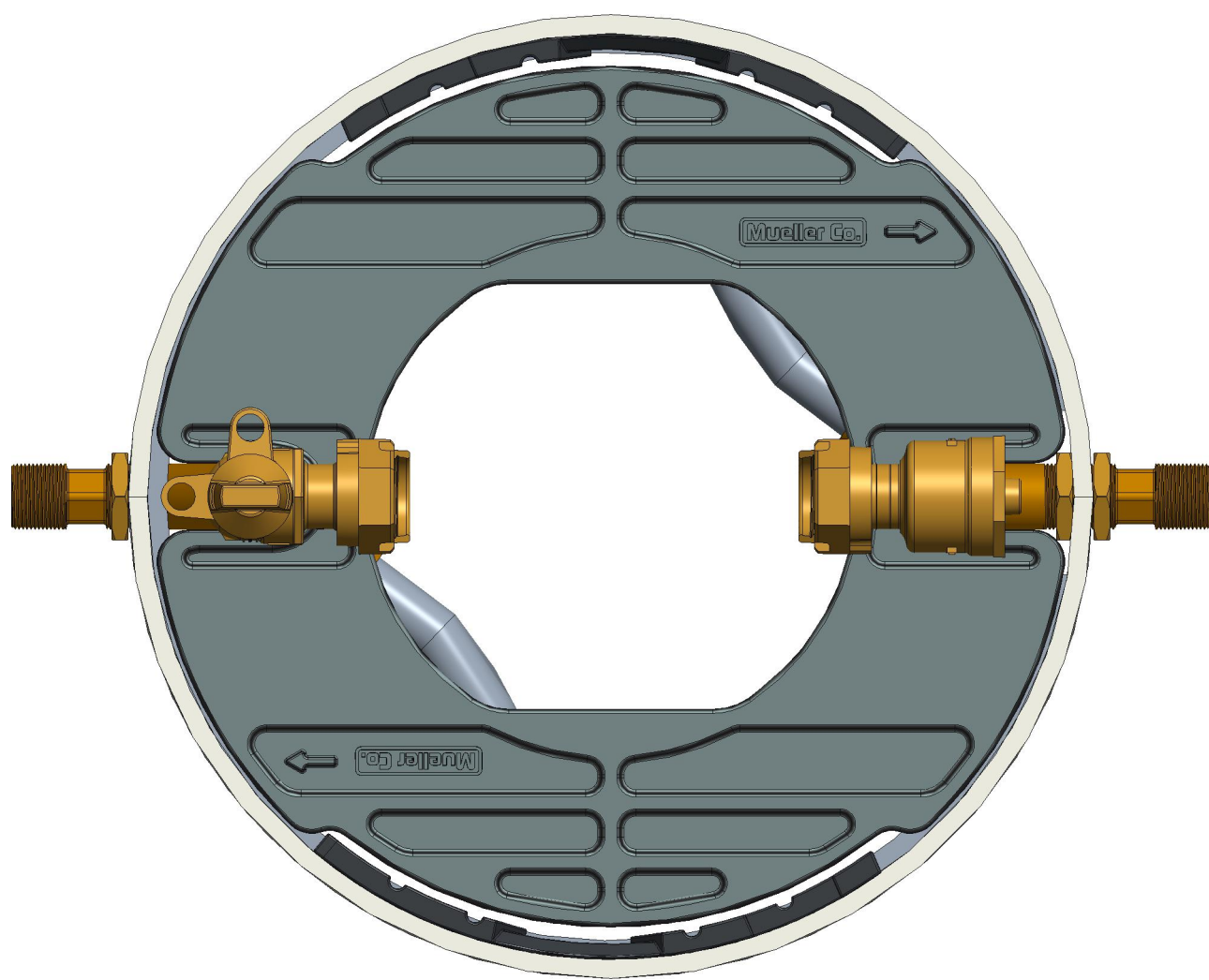
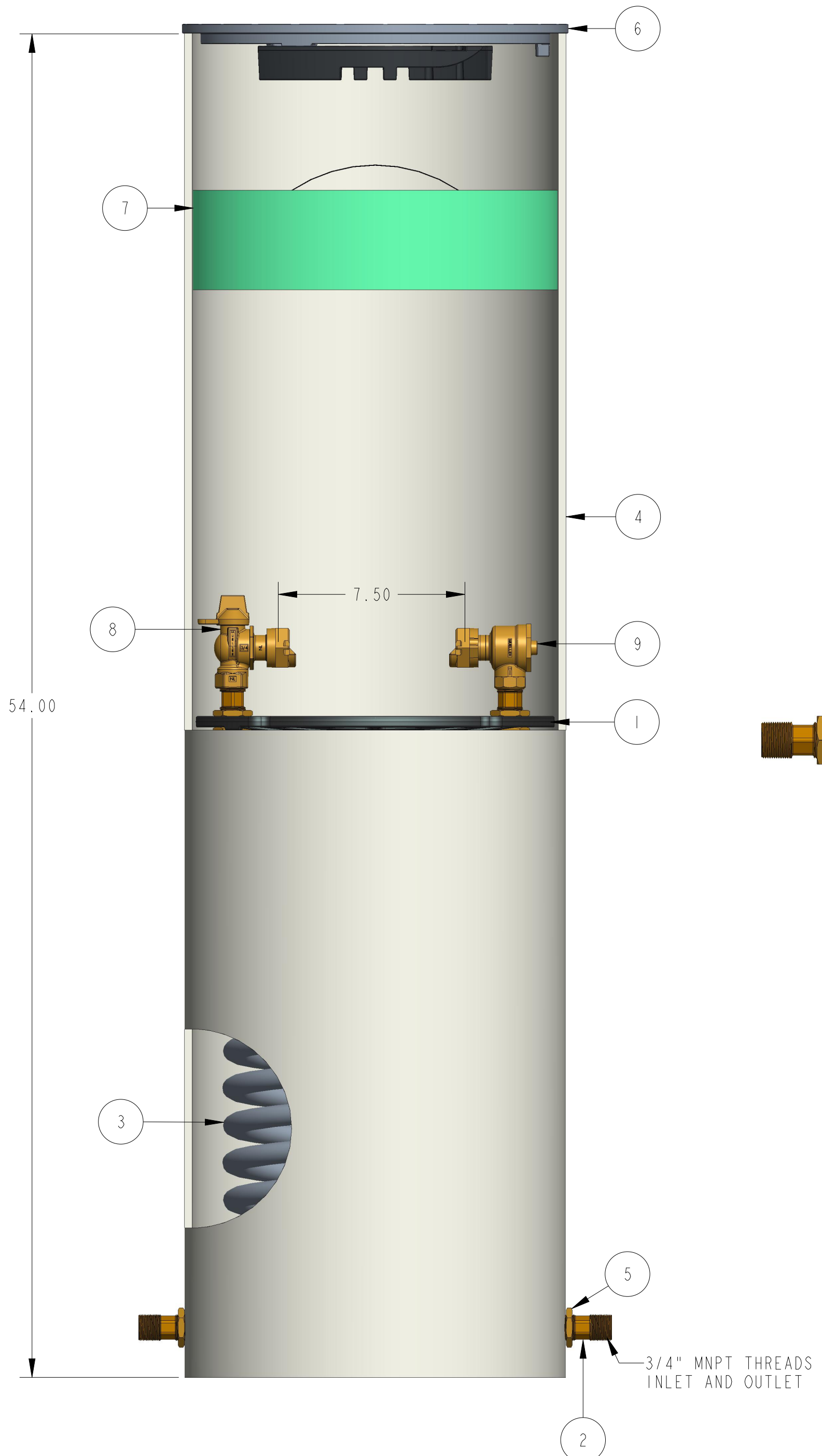

REVISIONS					
REV	ECR	DESCRIPTION	DRAWN BY	DATE	APPROVED
A		DRAWING CREATED	AOS	1/27/25	

TITLE TO AND OWNERSHIP OF THIS ENGINEERING DATA REMAINS IN Mueller Co. ABSENT ON THE PART OF THE RECIPIENT TO THESE CONDITIONS IS PRESUMED.

INTERPRET THIS DRAWING IN ACCORDANCE WITH ASME Y14.5 2018		NAME	DATE	THIRD ANGLE PROJECTION	
UNLESS OTHERWISE SPECIFIED DIMENSIONS ARE IN INCHES. MACHINING TOLERANCES:		DRAWN BY	AOS	Jan-27-25	
X ±.1	.015	D.E. APPR.			TITLE: <b>5/8"X3/4" COIL SINGLE METER PIT 15" DIA X 54" DEPTH LEAD FREE BRASS</b>
.XXX ±.005	.005	M.E. APPR.			
ANGULAR CORNER BREAK FINISH	±1° .015/.025 125 μin. RA	Q.A. APPR.			
DO NOT SCALE DRAWING				SIZE	DWG. NUMBER
MATERIAL:				C	203CS1554FBBSN
STK NUMBER:				SCALE: 0.063	REV A
REF.NO.				WT:	SHEET 1 OF 1