

ITEM NO	PART NUMBER	QTY	DESCRIPTION	MATERIAL
1	282924	1	CAST IRON LID (SOLD SEPERATELY)	CAST IRON
2	311965	1	15-10 ABS PLATFORM	PLASTIC VIRGIN POLYLAC, PA747 ABS BLACK RESIN OR PROOFED EQUIVALENT RESIN
3	700013_REVE	4	3/4" HOSE CONNECTOR	RED BRASS ASTM B43 ALLOY C23000 O61 TEMPER ANNEALED
4	780012-1560	2	3/4" COIL PART	POLYBUTYLENE RESIN BASELL AKOALIT PB4267 OR 4237 GREY
5	780021-1584	1	SHELL SUB ASSEMBLY	SDR-51 PVC PIPE ASTM D2241 GRADE 1120
6	790006	8	3/4" HEX NUT	ASTM B16 ALLOY C36000
7	790022	1	15" INSULATION PAD (SOLD SEPARATELY)	ETHAFOAM 220 WHITE OR POLYLAM 1.7 DENSITY WHITE
8	215B24265N	1	5/8" X 3/4" FULL PORT BALL VALVE	LEAD FREE BRASS ALLOY ASTM B584 C89833/C87850
9	215H14244	1	5/8" X3/4" DUAL CHECK VALVE	LEAD FREE BRASS ALLOY ASTM B584 C89833/C87850

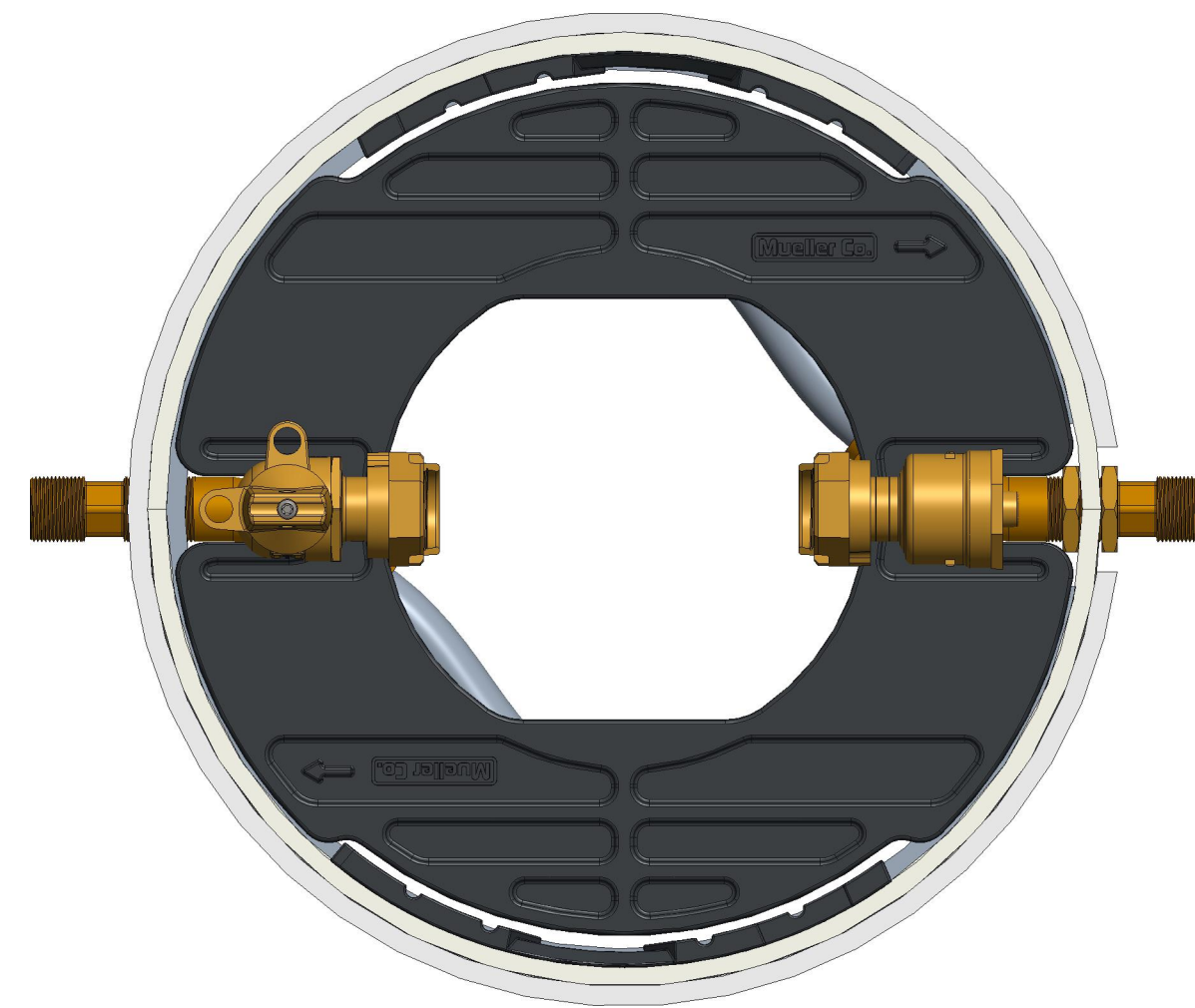

DR. BY	AOD	9/03/21	UNLESS OTHERWISE NOTED	THIRD ANGLE PROJECTION	C.B. NO.
CHKR			BREAK CAST CORNER(S)---		
ENGR			BREAK MACH CORNER(S)---	PURCH.	FINISH
MGR			TOLERANCES	REF. NO.	PATT. NO.
MFG			UNLESS OTHERWISE NOTED	SCALE	
TOOL			LINEAR	ANGULAR	
FDRY			±	±	STR. NO.
MAT'L:					
MUELLER			DESCR. 5/8"X3/4" COIL SINGLE METER PIT 18" DIA X 84" DEPTH LEAD FREE BRASS	NUMBER 203CS1584FBBSN	