

ITEM NO	PART NUMBER	QTY	DESCRIPTION	MATERIAL
1	700013_REVE	4	3/4" HOSE CONNECTOR	RED BRASS ASTM B43 ALLOY C23000 O61 TEMPER ANNEALED
2	700035-1560	2	3/4" COIL PART	POLYBUTYLENE RESIN BASELL AKOALIT PB4267 OR 4237 GREY
3	700058	1	PLATFORM	PASTIC VIRGIN POLYLAC, PA747 ABS BLACK RESIN OR PROOFED EQUIVALENT RESIN
4	700158	1	3/4" U-BAR	RED BRASS ASTM B43 ALLOY C23000 O61 TEMPER ANNEALED
5	780081-1860	1	SHELL SUB ASSEMBLY	SDR-51 PVC PIPE ASTM D2241 GRADE 1120
* 6	780113	1	18" DIA CAST IRON LID W/ RECESSED TR (SOLD SEPARATELY)	CAST IRON ASTM A125 CLASS B AND CAST BRONZE ASTM B584/B62 ALLOY C84400/C83600
7	790006	12	3/4" HEX NUT	ASTM B16 ALLOY C36000
* 8	790153	1	18" INSULATION PAD (SOLD SEPARATELY)	ETHAFOAM 220 WHITE OR POLYLAM 1.7 DENSITY WHITE
9	215HI4210	2	5/8" X 3/4" METER COUPLING (SWIVEL NUT)	LEAD FREE BRASS ALLOY ASTM B584 C89833/C87850
10	215HI4244	1	5/8" X3/4" DUAL CHECK VALVE	LEAD FREE BRASS ALLOY ASTM B584 C89833/C87850
11	215HI4265	1	3/4" ANGLE BALL VALVE	LEAD FREE BRASS ALLOY ASTM B584 C89833/C87850

*AIS EXEMPT WITH 790153 AND 780113 INSTALLED

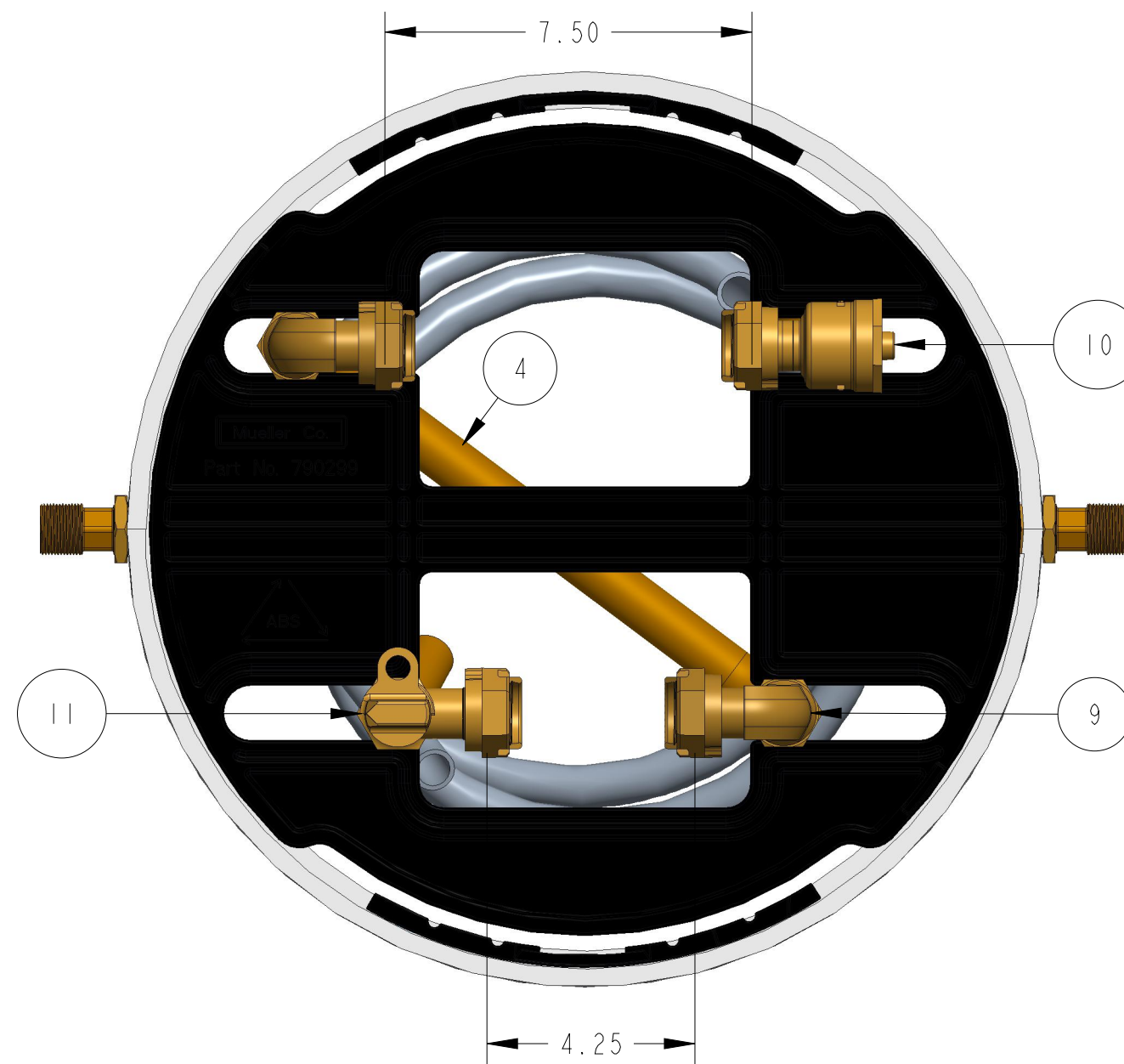

OPTION CODE 525:
* FOR 3/4" WATTS 70XLDM

DR. BY	AOD	4/27/22	UNLESS OTHERWISE NOTED	THIRD ANGLE PROJECTION	C.B. NO.
CHKR			BREAK CAST CORNER(S)---		
ENGR			BREAK MACH CORNER(S)---	PURCH.	FINISH
MGR			TOLERANCES	REF. NO.	SCALE
MFG			UNLESS OTHERWISE NOTED	STR. NO.	
TOOL			LINEAR	ANGULAR	
FDRY			±	±	
MAT'L:					
MUELLER			DESCR. 5/8" X3/4" COIL TANDEM METER PIT 18" DIS X 60" DEPTH LEAD FREE BRASS		NUMBER 203CT1860LBBS000525N-ART