

ITEM NO	PART NUMBER	QTY	DESCRIPTION
1	700014	4	1" HOSE CONNECTOR
2	700046-1874	2	1" COIL PART
3	700058	1	PLATFORM
4	700131	2	3/4" NIPPLE WITH WRENCH FLATS
5	700551	1	3/4" U-BAR
6	780029-1874	1	18" SHELL SUB ASSEMBLY
7	780069	1	18" DIA CENTER LOCKING LID (NOT INCLUDED)
8	790006	8	3/4" HEX NUT
9	790010	4	1" HEX NUT
10	790153	1	18" INSULATION PAD (SOLD SEPARATELY)
11	215B2426551RN	1	5/8" X 3/4" REDUCED PORT BALL VALVE
12	215H14210	2	5/8" X 3/4" METER COUPLING (SWIVEL NUT)
13	215H14244	1	5/8" X 3/4" DUAL CHECK VALVE
14	790059E	2	1" X 3/4" BELL REDUCER

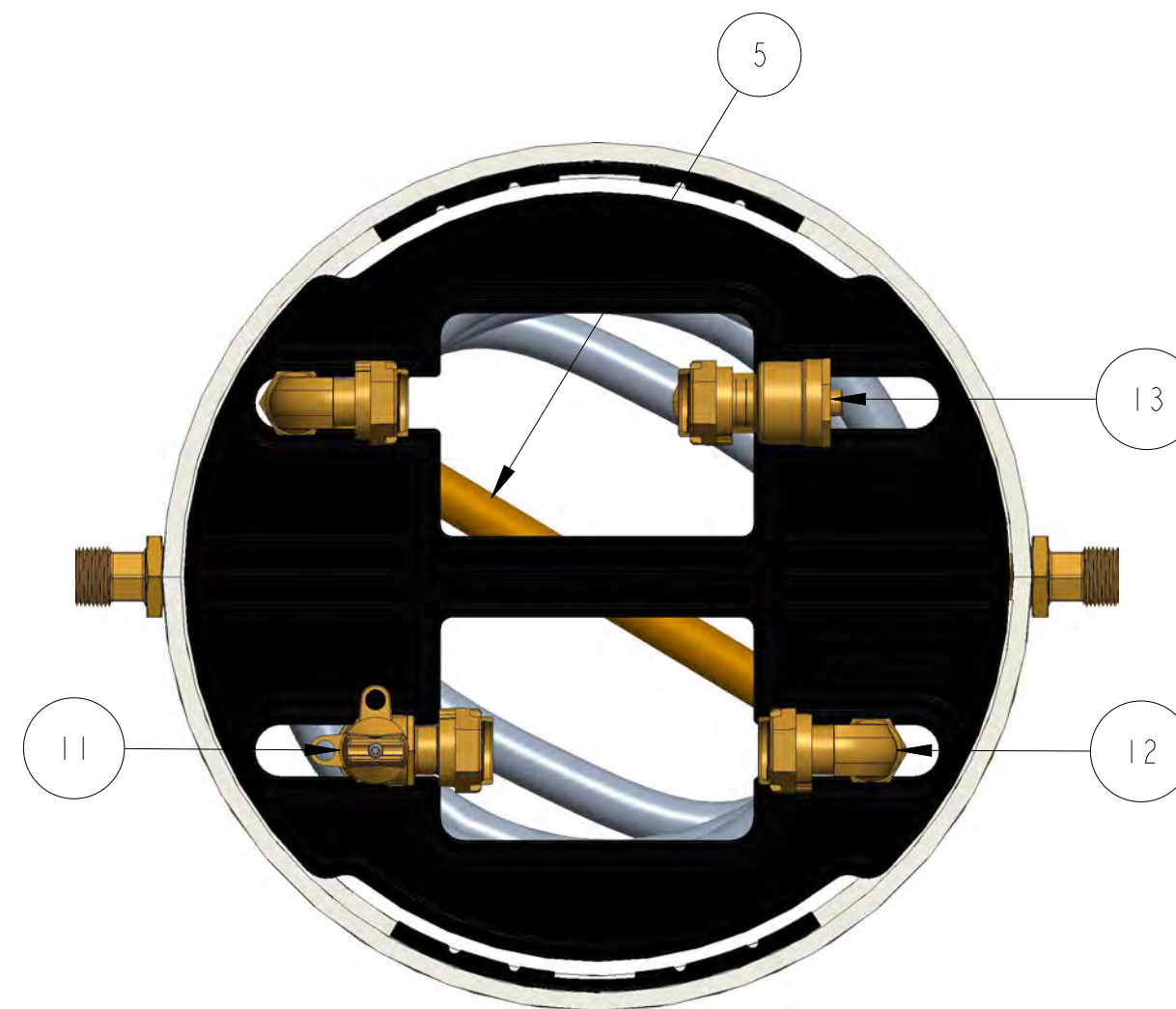

OPTION CODE 709:
 *1" COIL INSTEAD OF 3/4"
 *TANDEM FOR A WATTS 5M3-Z6 PRV
 *INSTALL LID 780069 PRIOR TO SHIPPING

DR. BY	AOD	12/30/21	UNLESS OTHERWISE NOTED		THIRD ANGLE PROJECTION		C.B. NO.
CHKR			BREAK CAST CORNER(S)---				
ENGR			BREAK MACH CORNER(S)---		PURCH.	FINISH	PATT. NO.
MGR			TOLERANCES		REF. NO.	SCALE	
MFG			UNLESS OTHERWISE NOTED				
TOOL			LINEAR	ANGULAR			
FDRY			±	±	STR. NO.		
MAT'L:							
MUELLER			DESCR. 5/8"X3/4" COIL TANDEM METER PIT 18" DIA X 74" DEPTH LOW LEAD BRASS				NUMBER 203CT1874RBBL000709N