

ITEM NO	PART NUMBER	QTY	DESCRIPTION	MATERIAL
1	311954	1	15" COMPOSITE SIDE LOCKING LID (SOLD SEPARATELY)	COMPOSITE
2	548204	1	STAINLESS STEEL BOTTOM (OPTIONAL)	STAINLESS STEEL
3	548357_151N	2	15" & 18" UNIVERSAL BRACKET	INJECTION MOLDED PLASTIC
4	700220	1	5/8" X 3/4" METER JUMPER	SCH 80 PVC PIPE
5	780077-1530	1	SHELL SUB ASSEMBLY	SDR-51 PVC PIPE ASTM D2241 GRADE 1120
6	790006	4	3/4" HEX NUT	ASTM B16 ALLOY C36000
7	790022	1	15" INSULATION PAD (SOLD SEPARATELY)	ETHAFOAM 220 WHITE OR POLYLAM 1.7 DENSITY WHITE
8	215B24265N	1	5/8" X 3/4" FULL PORT BALL VALVE	LEAD FREE BRASS ALLOY ASTM B584 C89833/C87850
9	215H14244AN	1	5/8" X 3/4" ASSE DUAL CHECK VALVE	LEAD FREE BRASS ALLOY ASTM B584 C89833/C87850
10	250BN0300V01 (C)	2	3/4" BULKHEAD NIPPLE	ASTM B43 SEAMLESS RED BRASS C23000 O61 TEMPER
11	250PP1425 (C)	2	3/4" PIPE PART	ASTM B43 BRASS ALLOY C23000 O61 TEMPER
12	790026E	2	3/4" FNPT THREADED ELBOW	LEAD FREE BRASS ASTM B584 C89833

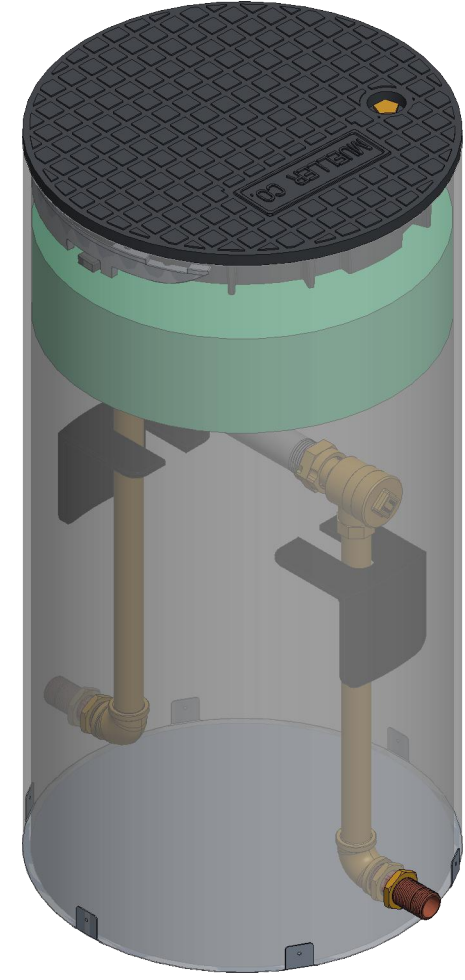
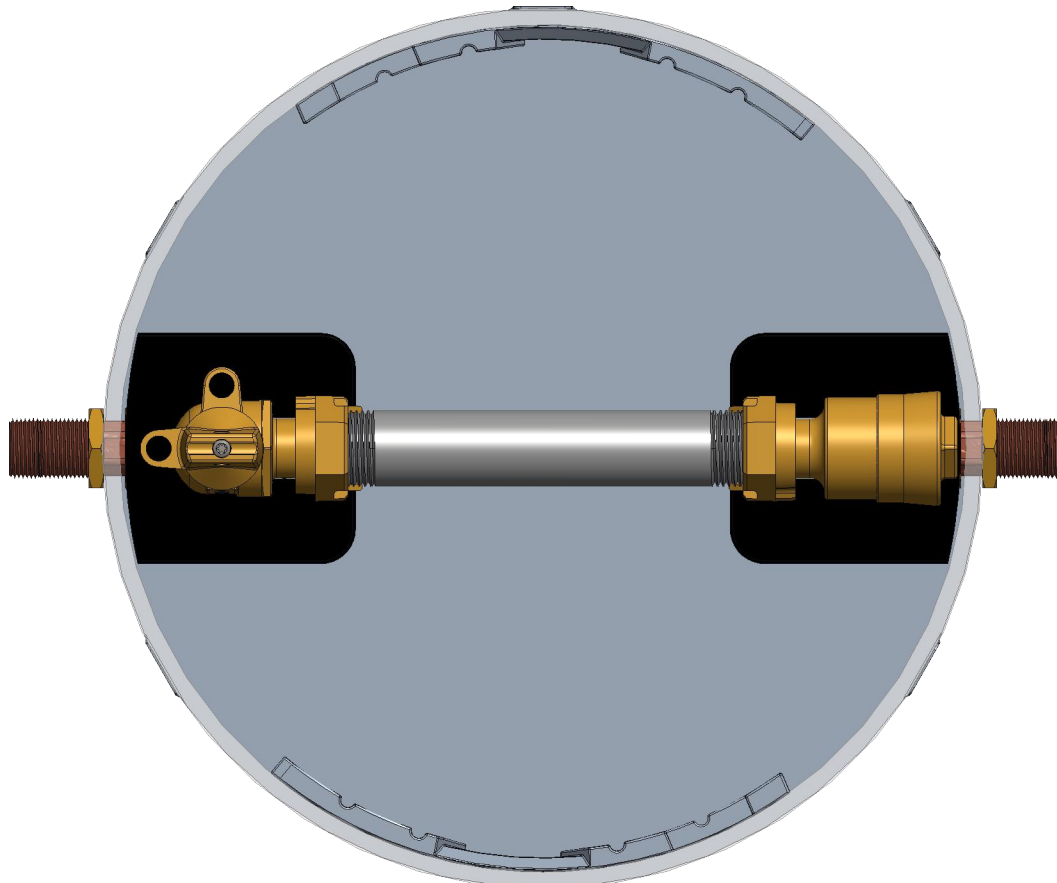

OPTION CODE 237:
 -CENTERLINE IS 12" FROM TOP OF PIT

REVISIONS					
REV	ECR	DESCRIPTION	DRAWN BY	DATE	APPROVED
B		552328 WAS 700265	JBK	9/07/23	
C		250PP1425 WAS 552328 250BN0300V01 WAS 700131	AOS	4/26/24	

INTERPRET THIS DRAWING IN ACCORDANCE WITH ASME Y14.5 2018		NAME	DATE	THIRD ANGLE PROJECTION	
D.E. APPR.	AOS	May-04-22			
M.E. APPR.					TITLE:
Q.A. APPR.					5/8"X3/4" RIGID SINGLE METER PIT 15" DIA X 30" DEPTH LEAD FREE BRASS
UNLESS OTHERWISE SPECIFIED DIMENSIONS ARE IN INCHES. MACHINING TOLERANCES:				DO NOT SCALE DRAWING	
X .XX	±.1				
.XXX	±.015				
	±.005				
ANGULAR CORNER BREAK FINISH	±1°				
	.015/.025				
	125 μin. RA				
MATERIAL:		SIZE	DWG. NUMBER	REV	
STK NUMBER:		C	203RS1530FSAS000237N	C	
REF.NO.	SCALE: 0.091	WT:	SHEET 1 OF 1		

TITLE TO AND OWNERSHIP OF THIS ENGINEERING DATA REMAINS IN Mueller Co. ABSENT ON THE PART OF THE RECIPIENT TO THESE CONDITIONS IS PRESUMED.