

ITEM NO	PART NUMBER	QTY	DESCRIPTION
1	203B24265RN	1	5/8" X 3/4" REDUCED PORT BALL VALVE
2	203H14244AN	1	5/8" X 3/4" ASSE ANGLE CHECK VALVE
3	215H14222	2	3/4" MULTI-PURPOSE X 3/4" FIP TAIL PIECE
4	532076E	1	METER BAR 3/4" MULTI-PURPOSE LLB
5	680005E	2	RISER SUB ASSEMBLY

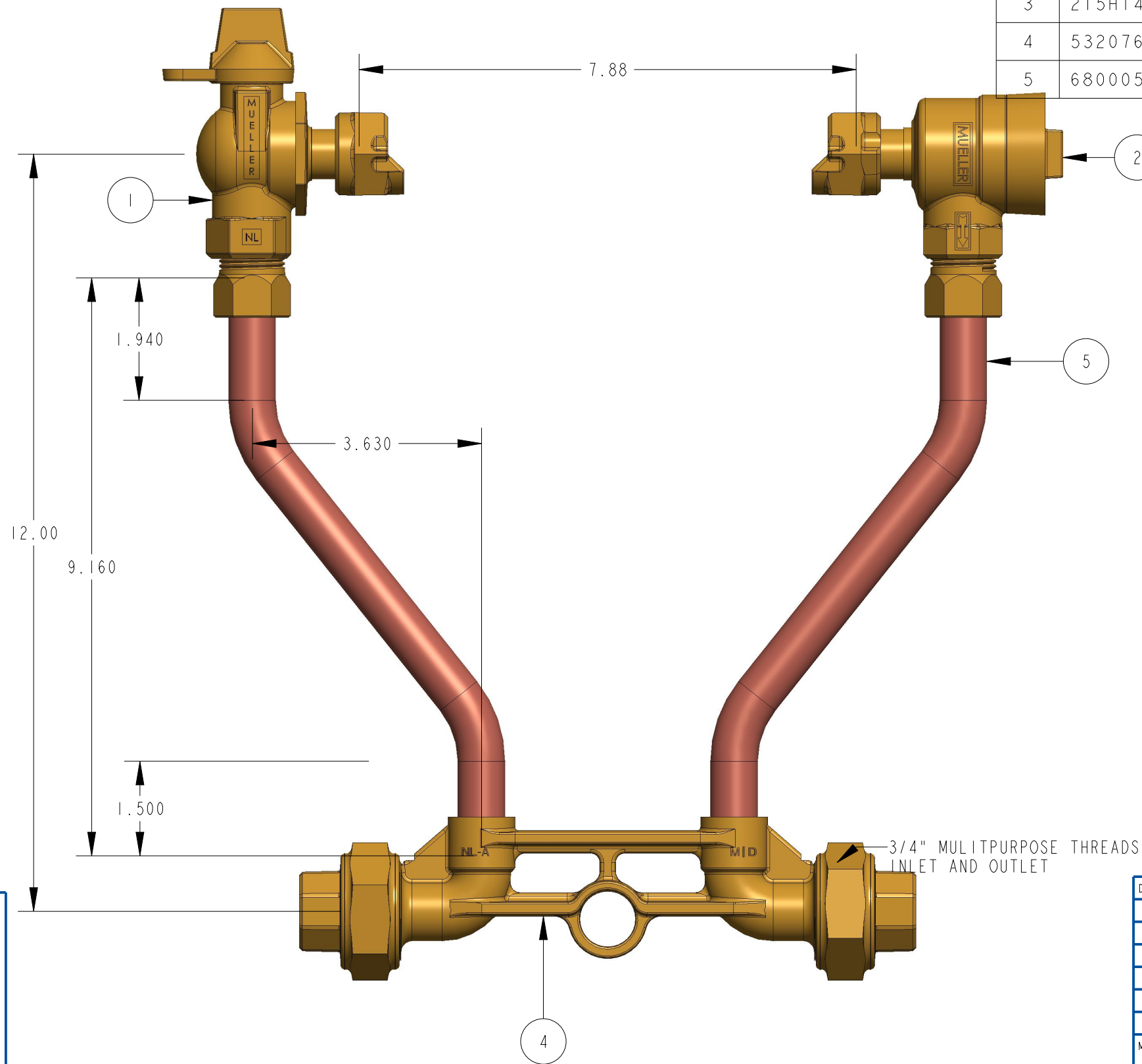

DR. BY	AOS	12/13/22	UNLESS OTHERWISE NOTED	THIRD ANGLE PROJECTION	C.B. NO.
CHKR			BREAK CAST CORNER(S)---		
ENGR			BREAK MACH CORNER(S)---	PURCH.	PATT. NO.
MGR			TOLERANCES	FINISH	
MFG			UNLESS OTHERWISE NOTED	REF. NO.	SCALE
TOOL			LINEAR		NONE
FDRY			±	ANGULAR	STK. NO.
MAT'L:					
MUELLER			DESCR. 5/8" COPPER METER SETTER 12" RISER HEIGHT LOW LEAD BRASS	NUMBER 225B2404-R2-14N	

225B2404-R2-14N

ITEM NO	PART NUMBER	QTY	DESCRIPTION	MATERIAL
1	203B24265RN	1	5/8" X 3/4" REDUCED PORT BALL VALVE	LEAD FREE BRASS ALLOY ASTM B584 C89833/C87850
2	203HI4244AN	1	5/8" X 3/4" ASSE ANGLE CHECK VALVE	LEAD FREE BRASS ALLOY ASTM B584 C89833/C87850
3	215HI4222	2	3/4" MULTI-PURPOSE X 3/4" FIP TAIL PIECE	LEAD FREE BRASS ALLOY ASTM B584 C89833/C87850
4	532076E	1	METER BAR 3/4" MULTI-PURPOSE LLB	LEAD FREE BRASS ALLOY ASTM B584 C89833/C87850
5	680005E	2	RISER SUB ASSEMBLY	COPPER TUBING ASTM B75 UNS C12200 050 TEMPER

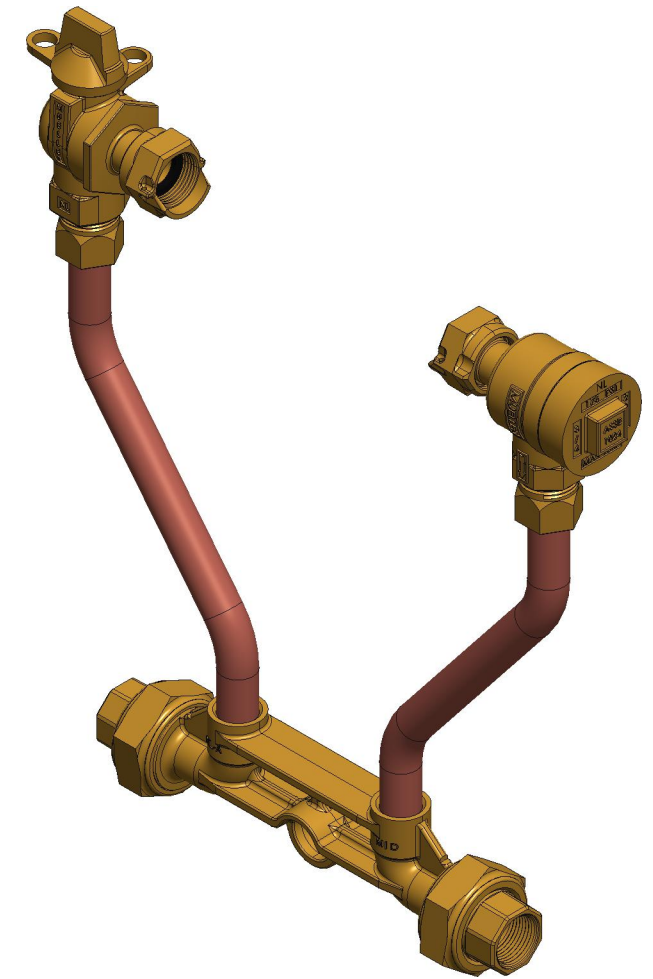
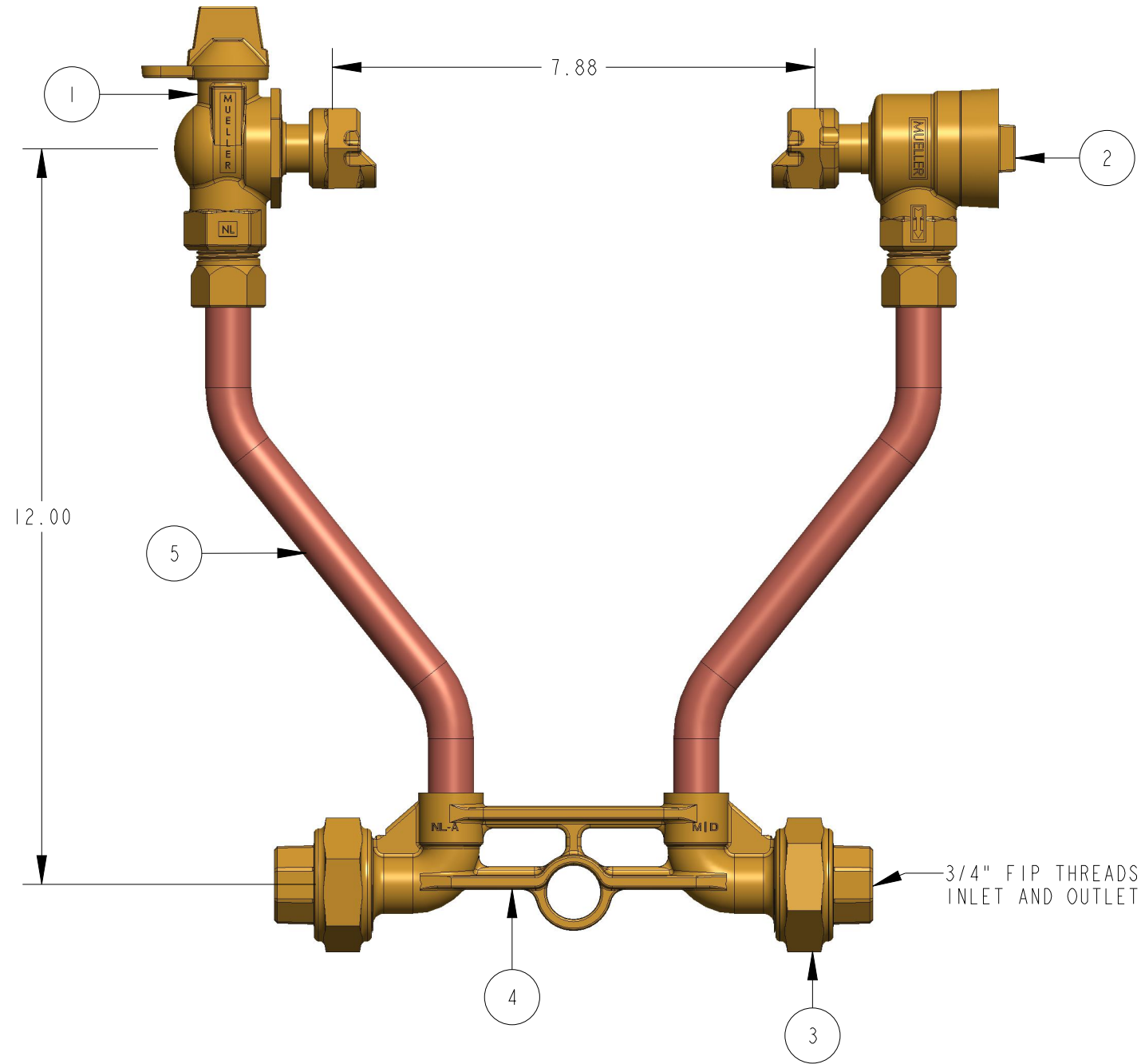

INTERPRET THIS DRAWING IN ACCORDANCE WITH ASME Y14.5 2018 UNLESS OTHERWISE SPECIFIED DIMENSIONS ARE IN INCHES. MACHINING TOLERANCES: .X ±.1 .XX ±.015 .XXX ±.005 ANGULAR CORNER BREAK FINISH ±1° .015/.025 125 µin. RA	NAME AOS	DATE Aug-09-24	THIRD ANGLE PROJECTION 		
	DRAWN BY AOS	D.E. APPR.	M.E. APPR.		TITLE: 5/8" COPPER METER SETTER 12" RISER HEIGHT LEAD FREE BRASS
	Q.A. APPR.	DO NOT SCALE DRAWING ○ = CRITICAL () = REFERENCE			SIZE B
	MATERIAL: 225B2404-R2-14N	DWG. NUMBER 225B2404-R2-14N	REV A		
STK NUMBER:	REF.NO.	SCALE: 0.167	WT:	SHEET 2 OF 2	

REVISIONS					
REV	ECR	DESCRIPTION	DRAWN BY	DATE	APPROVED
A		DRAWING CREATED	AOS	8/09/24	

TITLE TO AND OWNERSHIP OF THIS ENGINEERING DATA REMAINS IN Mueller Co. ASSENT ON THE PART OF THE RECIPIENT TO THESE CONDITIONS IS PRESUMED.

1 2 3 4 5 6

A

A

B

B

C

C

D

D

1 2 3 4 5 6