

ITEM NO	PART NUMBER	QTY	DESCRIPTION	MATERIAL
1	282927	1	LID WITH SIDE MOUNTED KEY LOCK	CAST IRON ASTM A126 CLASS B
2	700014	4	1" HOSE CONNECTOR	RED BRASS ASTM B43 ALLOY C23000 O61 TEMPER ANNEALED
3	700046-1884	2	1" COIL PART	SDR-51 PVC PIPE ASTM D2241 GRADE 1120
4	700058	1	PLATFORM	PASTIC VIRGIN POLYLAC, PA747 ABS BLACK RESIN OR PROOFED EQUIVALENT RESIN
5	700131	2	3/4" NIPPLE WITH WRENCH FLATS	RED BRASS ASTM B43 ALLOY C23000 O61 TEMPER ANNEALED
6	700551	1	3/4" U-BAR	RED BRASS ASTM B43 ALLOY C23000 O61 TEMPER ANNEALED
7	780029-1876	1	18" SHELL SUB ASSEMBLY	SDR-51 PVC PIPE ASTM D2241 GRADE 1120
8	790006	8	3/4" HEX NUT	ASTM B16 ALLOY C36000
9	790010	4	1" HEX NUT	ASTM B16 ALLOY C36000
10	790153	1	18" INSULATION PAD (SOLD SEPARATELY)	ETHAFOAM 220 WHITE OR POLYLAM 1.7 DENSITY WHITE
11	215B24265N	1	5/8" X 3/4" FULL PORT BALL VALVE	LEAD FREE BRASS ALLOY ASTM B584 C89833/C87850
12	215H14210	2	5/8" X 3/4" METER COUPLING (SWIVEL NUT)	LEAD FREE BRASS ALLOY ASTM B584 C89833/C87850
13	215H14244AN	1	5/8" X 3/4" ASSE DUAL CHECK VALVE	LEAD FREE BRASS ALLOY ASTM B584 C89833/C87850
14	790059E	2	1" X 3/4" BELL REDUCER	LEAD FREE BRASS ALLOY ASTM B584 C89833/C87850

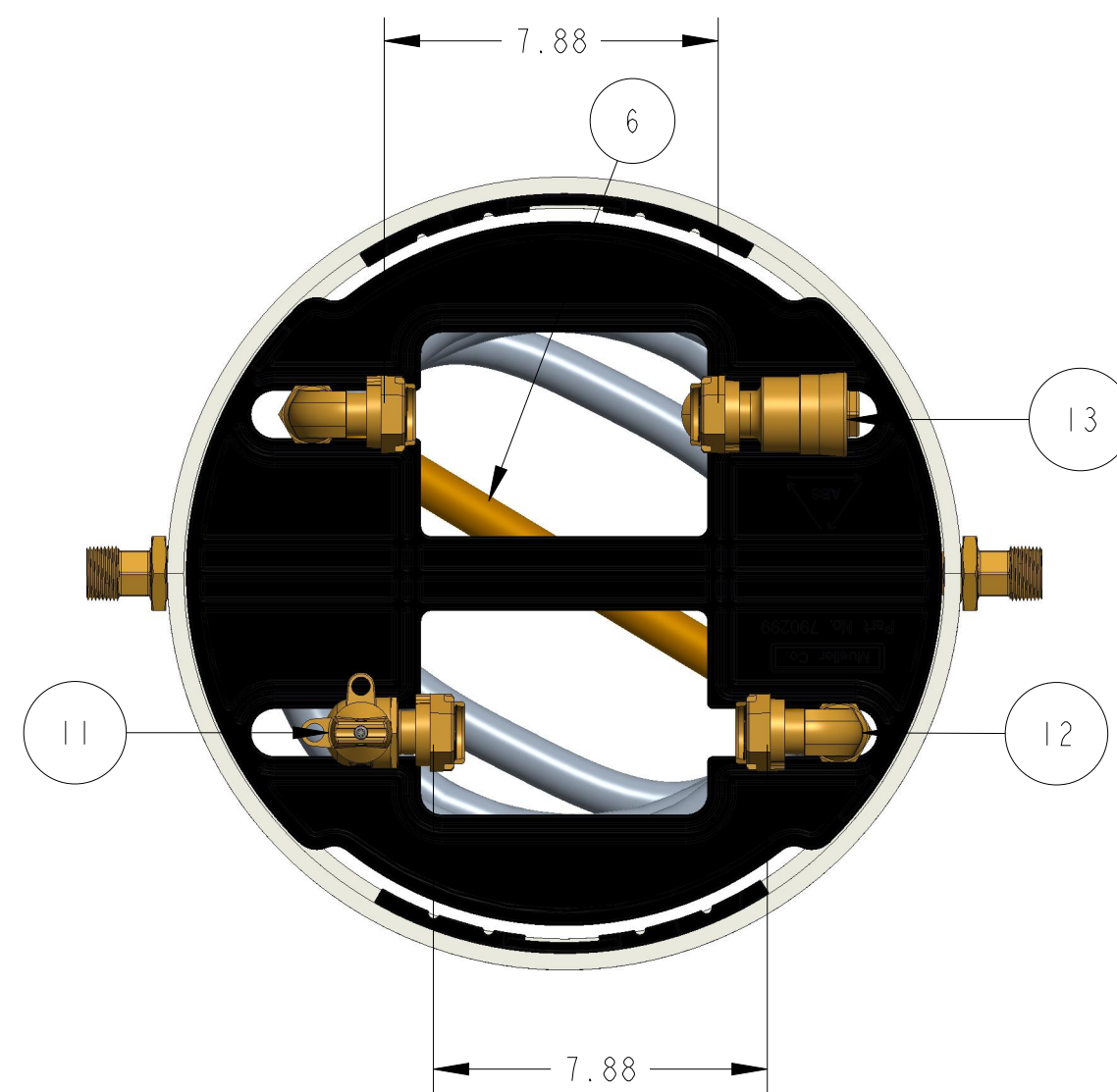

OPTION CODE 61:  
 \*1" COIL INSTEAD OF 3/4"  
 \*TANDEM FOR A WATTS 5M3-Z6 PRV

(B)  
 REMOVED BOTTOM  
 JBK 12/2/22

DR. BY	AOD	12/31/21	UNLESS OTHERWISE NOTED	THIRD ANGLE PROJECTION	C.B. NO.
CHKR			BREAK CAST CORNER(S)---		
ENGR			BREAK MACH CORNER(S)---	PURCH.	FINISH
MGR			TOLERANCES	REF. NO.	SCALE
MFG			UNLESS OTHERWISE NOTED	STR. NO.	
TOOL			LINEAR	ANGULAR	
FDRY			±	±	
MAT'L:					
<b>MUELLER</b>			DESCR. 3/4" COIL TANDEM METER PIT 18" DIA X 76" DEPTH LOW LEAD BRASS		NUMBER 250CT1876FSBN00006IN