

ITEM NO	PART NUMBER	QTY	DESCRIPTION	MATERIAL
1	311968	1	18-10 ABS PLATFORM	PLASTIC VIRGIN POLYLAC, PA747 ABS BLACK RESIN OR PROOFED EQUIVALENT RESIN
2	545215-1812	1	17" INSIDE CARTRIDGE - 12" RISE	PVC PIPE
3	545216	3	T-NUT	STAINLESS STEEL
4	545217	3	STAINLESS STEEL WASHER	STAINLESS STEEL
5	545218	3	3/8-16 SHOULDER BOLT	STAINLESS STEEL
6	548357	2	15" & 18" UNIVERSAL BRACKET	INJECTION MOLDED PLASTIC
7	700014	4	1" HOSE CONNECTOR	RED BRASS ASTM B43 ALLOY C23000 O61 TEMPER ANNEALED
8	700046-1848	2	1" COIL PART	POLYBUTYLENE RESIN BASELL AKOALIT PB4267 OR 4237 GREY
9	780113	1	18" DIA CAST IRON LID W/ RECESSED TR (SOLD SEPARATELY)	CAST IRON ASTM A125 CLASS B AND CAST BRONZE ASTM B584/B62 ALLOY C84400/C83600
10	790010	8	1" HEX NUT	ASTM B16 ALLOY C36000
11	790011-1848	1	18" ADJUSTA-SHELL ASSEMBLY 48"-60"	SDR-51 PVC PIPE ASTM D2241 GRADE 1120
12	790153	1	18" INSULATION PAD (SOLD SEPARATELY)	ETHAFOAM 220 WHITE OR POLYLAM 1.7 DENSITY WHITE
13	330B24265	1	1" FULL PORT BALL VALVE	LEAD FREE BRASS ALLOY ASTM B584 C89833/C87850
14	330H14244AN	1	1" ANGLE DUAL CHECK ASSE APPROVED LLB	LEAD FREE BRASS ALLOY ASTM B584 C89833/C87850

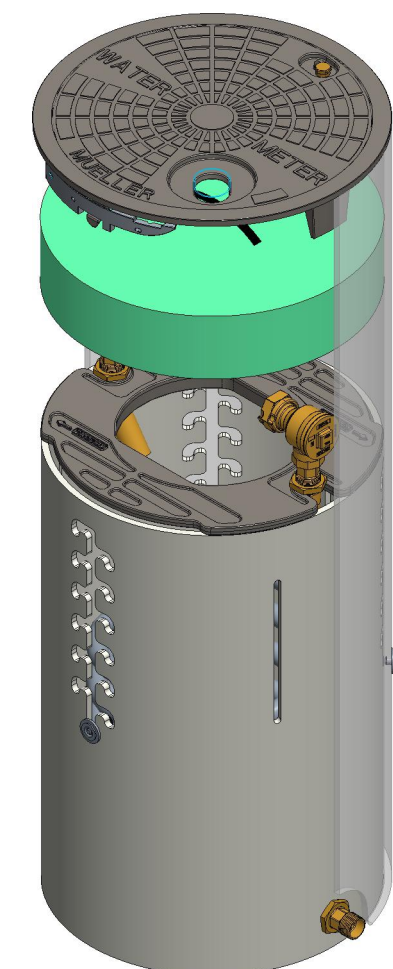
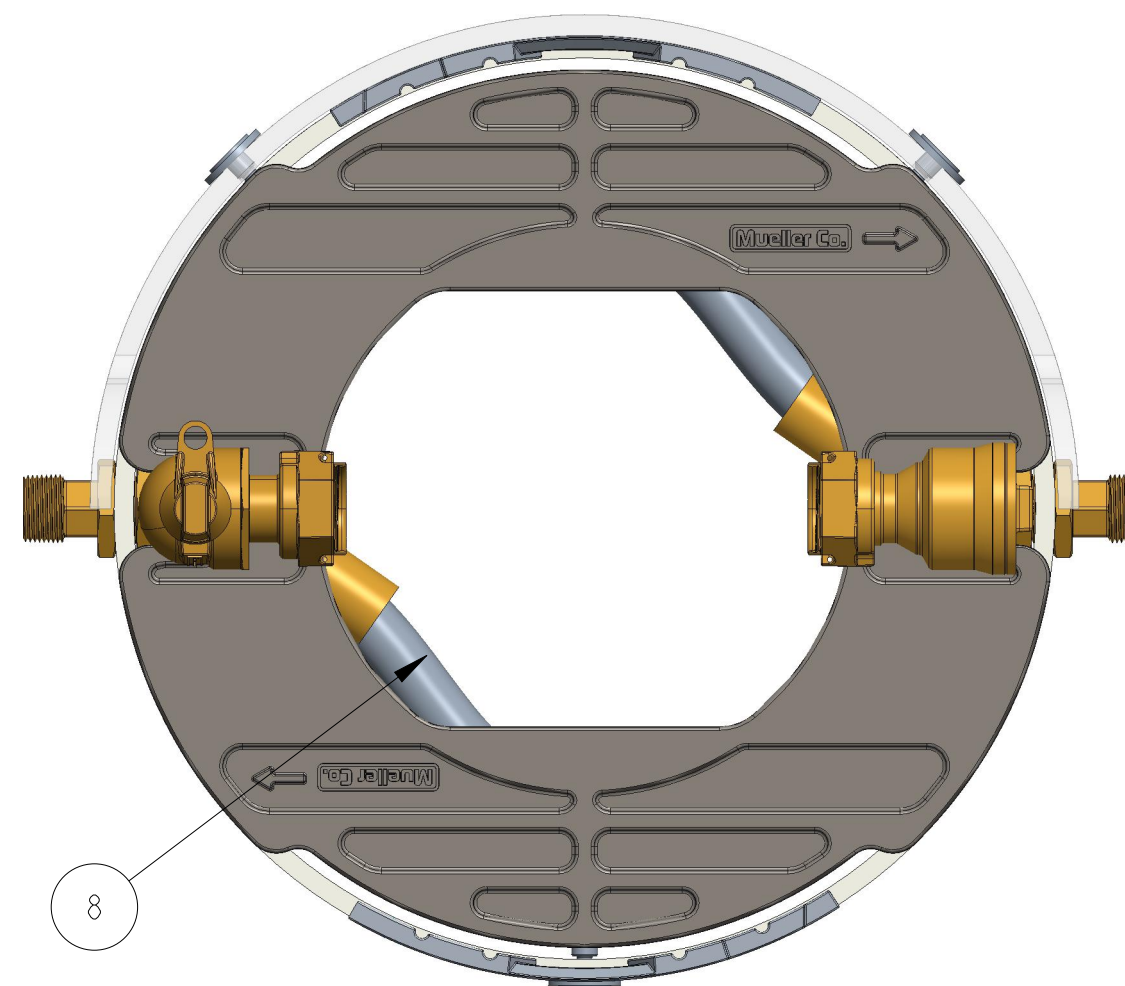

DR. BY	AOD	8/26/21	UNLESS OTHERWISE NOTED	THIRD ANGLE PROJECTION	C.B. NO.
CHKR			BREAK CAST CORNER(S)---		
ENGR			BREAK MACH CORNER(S)---	PURCH.	FINISH
MGR			TOLERANCES	REF. NO.	PATT. NO.
MFG			UNLESS OTHERWISE NOTED	SCALE	
TOOL			LINEAR	ANGULAR	
FDRY			±	±	STR. NO.
MAT'L:					
<b>MUELLER</b>		DESCR. 1" ADJUSTABLE SINGLE METER PIT 18" DIA X 48-60" DEPTH LEAD FREE BRASS		NUMBER 330AS184860FSBSN	