

ITEM NO	PART NUMBER	QTY	DESCRIPTION	MATERIAL
1	094987	2	1" FNPT ELBOW	CAST BRONZE ASTM B584 ALLOY C89833
2	548451	1	1" EXTENDED THREADED CONNECTOR	RED BRASS ASTM B43 ALLOY C23000 O61 TEMPER ANNEALED
3	548593	1	21" STEEL PLATFORM	RILSAN COATED A36 CARBON STEEL
4	548605	2	NIPPLE 1" X 1-3/8"	RED BRASS ASTM B43 ALLOY C23000 O61 TEMPER ANNEALED
5	700014	5	1" HOSE CONNECTOR	RED BRASS ASTM B43 ALLOY C23000 O61 TEMPER ANNEALED
6	700024-2142	1	SHELL SUB-ASSEMBLY	SDR-51 PVC PIPE ASTM D2241 GRADE 1120
7	700046-1842	3	COIL PART	PB 2110 CL 250 SDR-9
8	700098-1	1	CAST IRON FRAME (PURCHASED SEPARATELY)	CAST IRON ASTM A48 CLASS 25A
9	700261	1	REINFORCING RING	SDR-51 PVC PIPE ASTM D2241 GRADE 1120
10	700581	2	1" X 3-3/4" NIPPLE WITH FLATS	RED BRASS ASTM B43 ALLOY C23000 O61 TEMPER ANNEALED
11	780113	1	18" DIA CAST IRON LID W/ RECESSED TR (SOLD SEPARATELY)	CAST IRON ASTM A125 CLASS B AND CAST BRONZE ASTM B584/B62 ALLOY C84400/C83600
12	790010	14	1" HEX NUT	ASTM B16 ALLOY C36000
13	790322	1	21" X 4" EZ INSULATING PAD (ORDER SEPARATELY)	ETHAFOAM 220 WHITE OR POLYLAM 1.7 DENSITY WHITE
14	047169E	1	1" X 1-1/2" HEX BUSHING	CAST BRONZE ASTM B584 ALLOY C89833
15	094986E	1	1" FNPT THREADED TEE	ASTM B62 ALLOY C83600 OR ASTM B16 ALLOY C36000
16	330B24265	4	1" FULL PORT BALL VALVE	LEAD FREE BRASS ALLOY ASTM B584 C89833/C87850

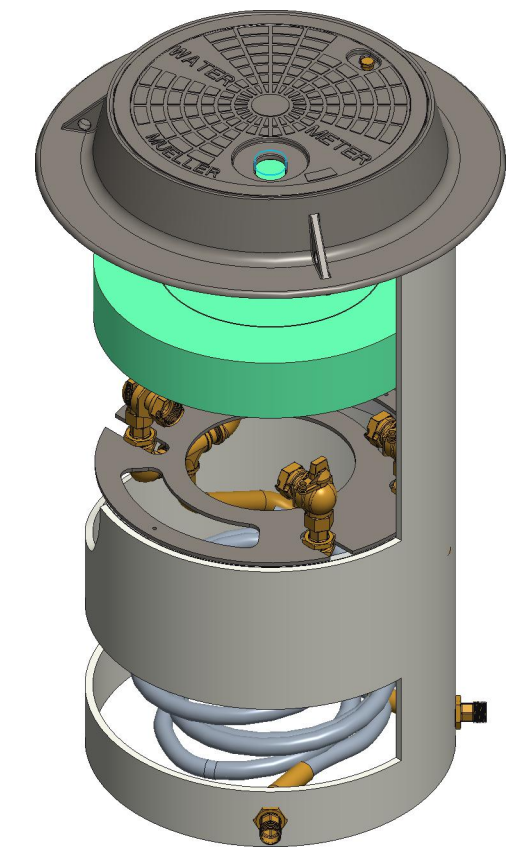
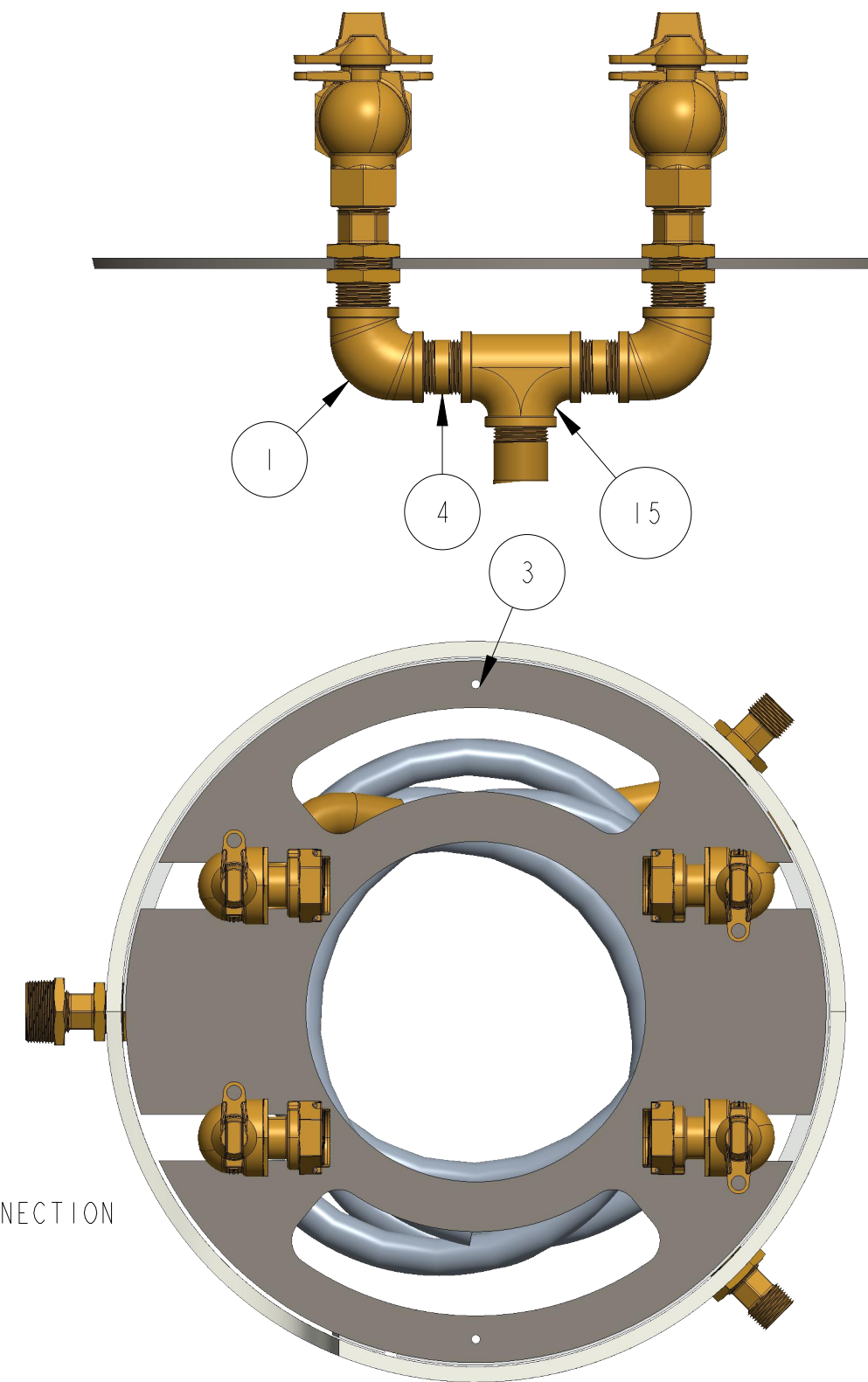

OPTION CODE 715:
*1-1/2" INLET

DR. BY	AOD	8/04/21	UNLESS OTHERWISE NOTED	THIRD ANGLE PROJECTION	C.B. NO.
CHKR			BREAK CAST CORNER(S)---		
ENGR			BREAK MACH CORNER(S)---	PURCH.	FINISH
MGR			TOLERANCES	REF. NO.	PATT. NO.
MFG			UNLESS OTHERWISE NOTED	SCALE	
TOOL			LINEAR	ANGULAR	
FDRY			±	±	STR. NO.
MAT'L:					
MUELLER			DESCR. 1" COIL DOUBLE METER PIT 21" DIA X 42" DEPTH LOW LEAD BRASS		NUMBER 330CD2142FFBSN000715N