

ITEM NO	PART NUMBER	QTY	DESCRIPTION	MATERIAL
1	311955	1	18" DIA SIDE LOCKING COMPOSITE LID (SOLD SEPARATELY)	COMPOSITE MATERIAL
2	311968	1	18-10 ABS PLATFORM	PLASTIC VIRGIN POLYLAC, PA747 ABS BLACK RESIN OR PROOFED EQUIVALENT RESIN
3	700014	2	1" HOSE CONNECTOR	RED BRASS ASTM B43 ALLOY C23000 O61 TEMPER ANNEALED
4	700014-NF	2	CONNECTOR 1" W/O FLAT	RED BRASS ASTM B43 ALLOY C23000 O61 TEMPER ANNEALED
5	700046-1860	2	COIL PART	POLYBUTYLENE RESIN BASELL AKOALIT PB4267 OR 4237 GREY
6	780029-1860	1	18" SHELL SUB ASSEMBLY	SDR-51 PVC PIPE ASTM D2241 GRADE 1120
7	790010	6	1" HEX NUT	ASTM B16 ALLOY C36000
8	790153	1	18" INSULATION PAD (SOLD SEPARATELY)	ETHAFOAM 220 WHITE OR POLYLAM 1.7 DENSITY WHITE
9	330B24265	1	1" FULL PORT BALL VALVE	LEAD FREE BRASS ALLOY ASTM B584 C89833/C87850
10	330H14211N	2	1" UNION	LEAD FREE BRASS ALLOY ASTM B584 C89833/C87850
11	330H14244AN	1	1" ANGLE DUAL CHECK ASSE APPROVED LLB	LEAD FREE BRASS ALLOY ASTM B584 C89833/C87850

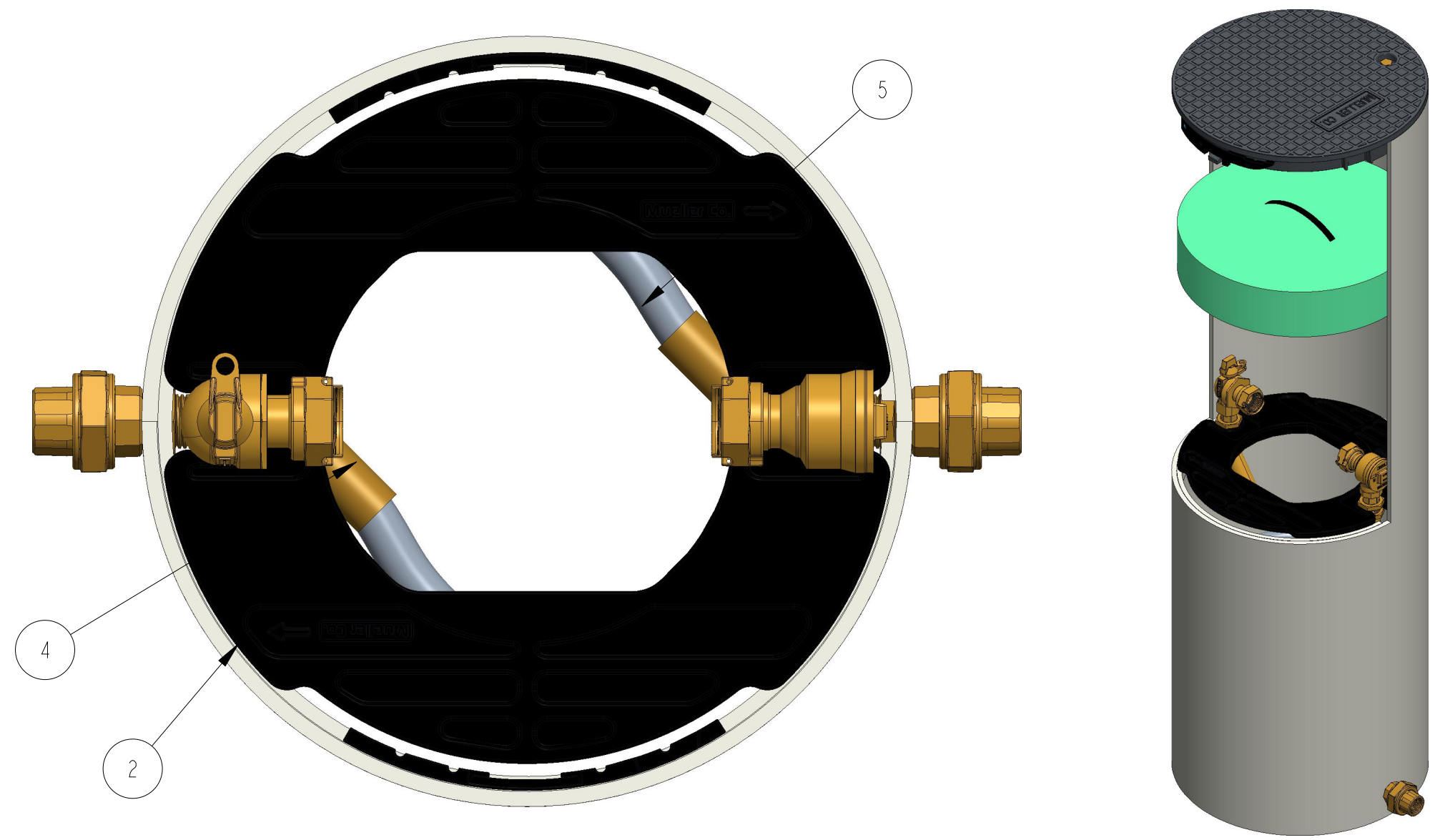

OPTION CODE: 390  
 \*UNIONS INSTALLED ON INLET & OUTLET  
 \*NO EXPOSED THREADS OUTSIDE OF SHELL  
 \*USE OLD STYLE CONNECTOR

DR. BY	AOD	7/27/21	UNLESS OTHERWISE NOTED	THIRD ANGLE PROJECTION	C.B. NO.
CHKR			BREAK CAST CORNER(S)---		
ENGR			BREAK MACH CORNER(S)---	PURCH.	FINISH
MGR			TOLERANCES	REF. NO.	SCALE
MFG			UNLESS OTHERWISE NOTED	STR. NO.	
TOOL			LINEAR	ANGULAR	
FDRY			±	±	
MAT'L:					
<b>MUELLER</b>			DESCR. 1" COIL SINGLE METER PIT 18" DIA X 60" DEPTH LEAD FREE BRASS		NUMBER 330CS1860FSBS000390N