

ITEM NO	PART NUMBER	QTY	DESCRIPTION	MATERIAL
1	311955	1	18" DIA SIDE LOCKING COMPOSITE LID (SOLD SEPARATELY)	COMPOSITE MATERIAL
2	311968	1	18-10 ABS PLATFORM	PLASTIC VIRGIN POLYLAC, PA747 ABS BLACK RESIN OR PROOFED EQUIVALENT RESIN
3	700014	4	1" HOSE CONNECTOR	RED BRASS ASTM B43 ALLOY C23000 O61 TEMPER ANNEALED
4	700046-1896	2	COIL PART	POLYBUTYLENE RESIN BASELL AKOALIT PB4267 OR 4237 GREY
5	780023-1896	1	SHELL SUB ASSEMBLY	SDR-51 PVC PIPE ASTM D2241 GRADE 1120
6	790010	8	1" HEX NUT	ASTM B16 ALLOY C36000
7	790153	1	18" INSULATION PAD (SOLD SEPARATELY)	ETHAFOAM 220 WHITE OR POLYLAM 1.7 DENSITY WHITE
8	330B24265	1	1" FULL PORT BALL VALVE	LEAD FREE BRASS ALLOY ASTM B584 C89833/C87850
9	330H14244AN	1	1" ANGLE DUAL CHECK ASSE APPROVED LLB	LEAD FREE BRASS ALLOY ASTM B584 C89833/C87850

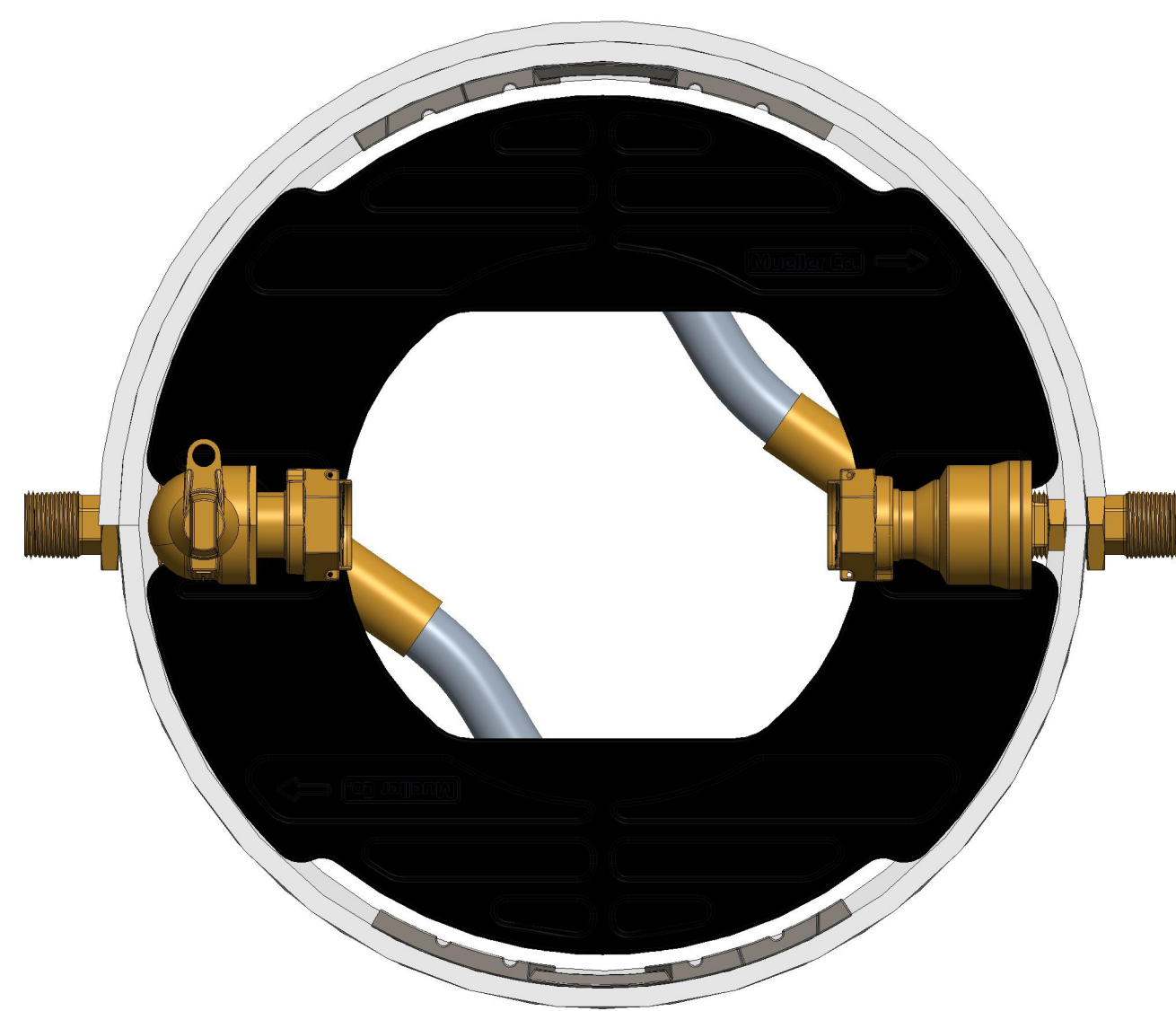
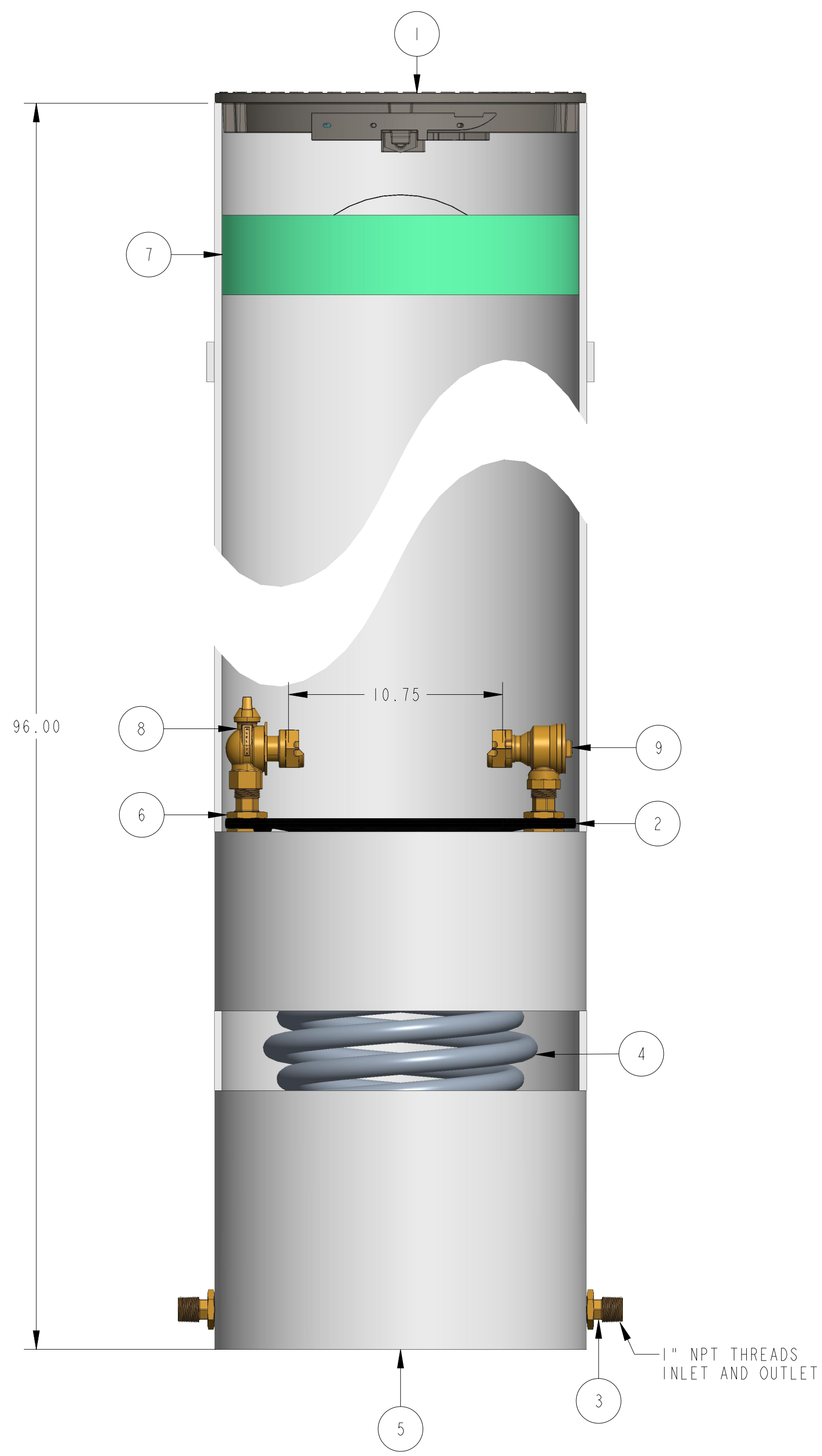

REVISIONS					
REV	ECR	DESCRIPTION	DRAWN BY	DATE	APPROVED
A		DRAWING CREATED	AOS	7/24/24	

TITLE TO AND OWNERSHIP OF THIS ENGINEERING DATA REMAINS IN Mueller Co. ASSENT ON THE PART OF THE RECIPIENT TO THESE CONDITIONS IS PRESUMED.

INTERPRET THIS DRAWING IN ACCORDANCE WITH ASME Y14.5 2018		NAME	DATE	THIRD ANGLE PROJECTION	
UNLESS OTHERWISE SPECIFIED DIMENSIONS ARE IN INCHES. MACHINING TOLERANCES:		DRAWN BY	AOS	Jul-24-24	
X ±1	±.015	D.E. APPR.			
.XX ±.005	±.005	M.E. APPR.			
ANGULAR CORNER BREAK FINISH ±1° .015/.025 125 μm. RA		Q.A. APPR.			TITLE:
DO NOT SCALE DRAWING					1" COIL SINGLE METER PIT 18" DIA X 96" DEPTH LEAD FREE BRASS
MATERIAL:		SIZE		DWG. NUMBER	REV
STK NUMBER:		C		330CS1896XSBSN	A
REF. NO.		SCALE: 0.048		WT:	SHEET 1 OF 1