

330CT1872FSAS000044N

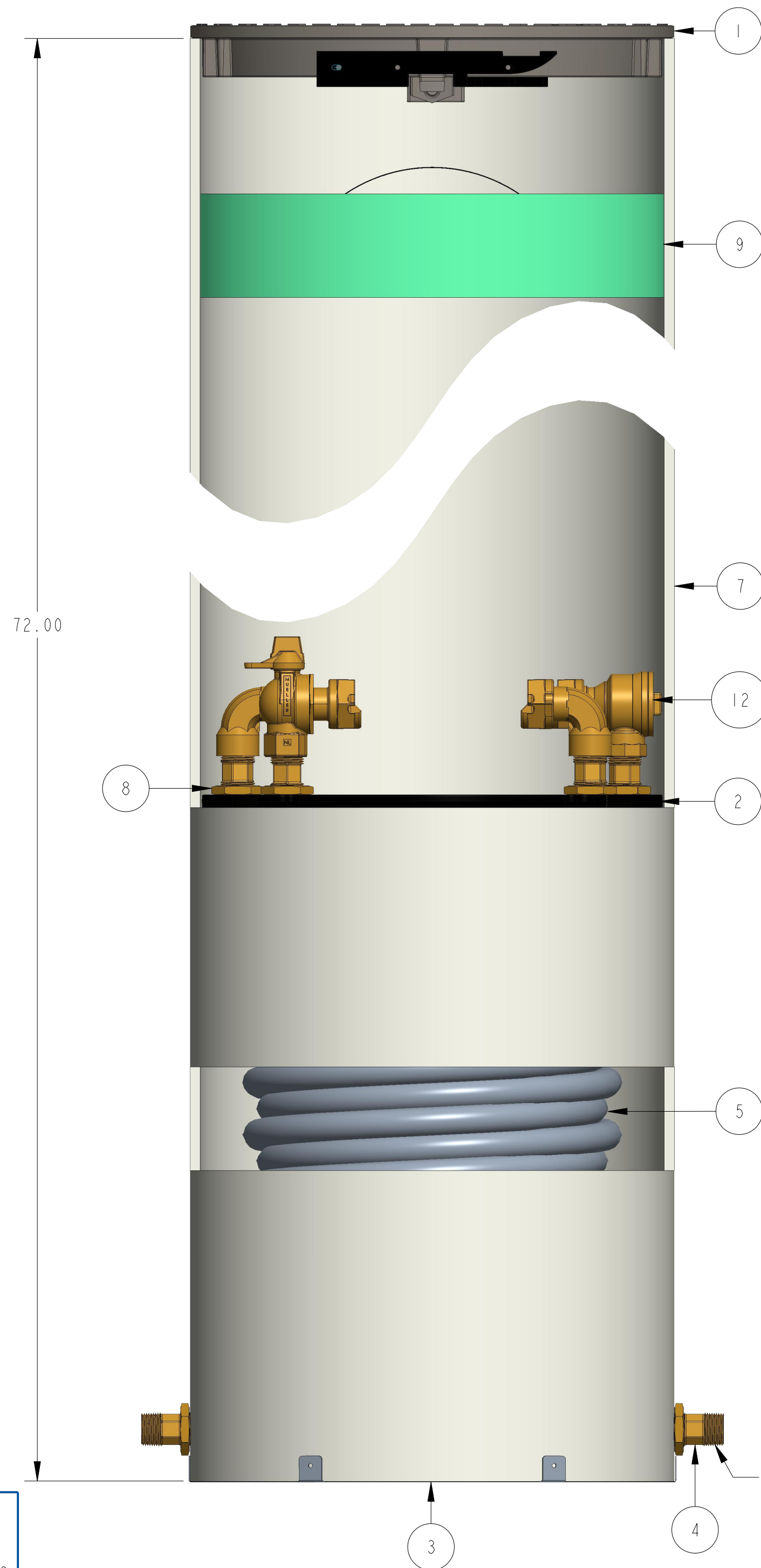

ITEM NO	PART NUMBER	QTY	DESCRIPTION	MATERIAL
1	311955	1	18" DIA SIDE LOCKING COMPOSITE LID (SOLD SEPARATELY)	COMPOSITE MATERIAL
2	311980 (B)	1	18IN ABS PLATFORM 18-25	PLASTIC VIRGIN POLYLAC, PA747 ABS BLACK RESIN OR PROOFED EQUIVALENT RESIN
3	548206	1	18" DIA STAINLESS STEEL BOTTOM	STAINLESS STEEL SHEET METAL
4	700014	4	1" HOSE CONNECTOR	RED BRASS ASTM B43 ALLOY C23000 O61 TEMPER ANNEALED
5	700046-1884	2	1" COIL PART	SDR-51 PVC PIPE ASTM D2241 GRADE 1120
6	700380	1	1" U BAR	RED BRASS ASTM B43 ALLOY C23000 O61 TEMPER ANNEALED
7	780029-1872	1	18" SHELL SUB ASSEMBLY	SDR-51 PVC PIPE ASTM D2241 GRADE 1120
8	790010	8	1" HEX NUT	ASTM B16 ALLOY C36000
9	790153	1	18" INSULATION PAD (SOLD SEPARATELY)	ETHAFOAM 220 WHITE OR POLYLAM 1.7 DENSITY WHITE
10	330B242653N	1	1" FULL PORT 360 BALL VALVE	LEAD FREE BRASS ALLOY ASTM B584 C89833/C87850
11	330H14210	2	1" METER COUPLING	LEAD FREE BRASS ALLOY ASTM B584 C89833/C87850
12	330H14244AN	1	1" ANGLE DUAL CHECK ASSE APPROVED LLB	LEAD FREE BRASS ALLOY ASTM B584 C89833/C87850

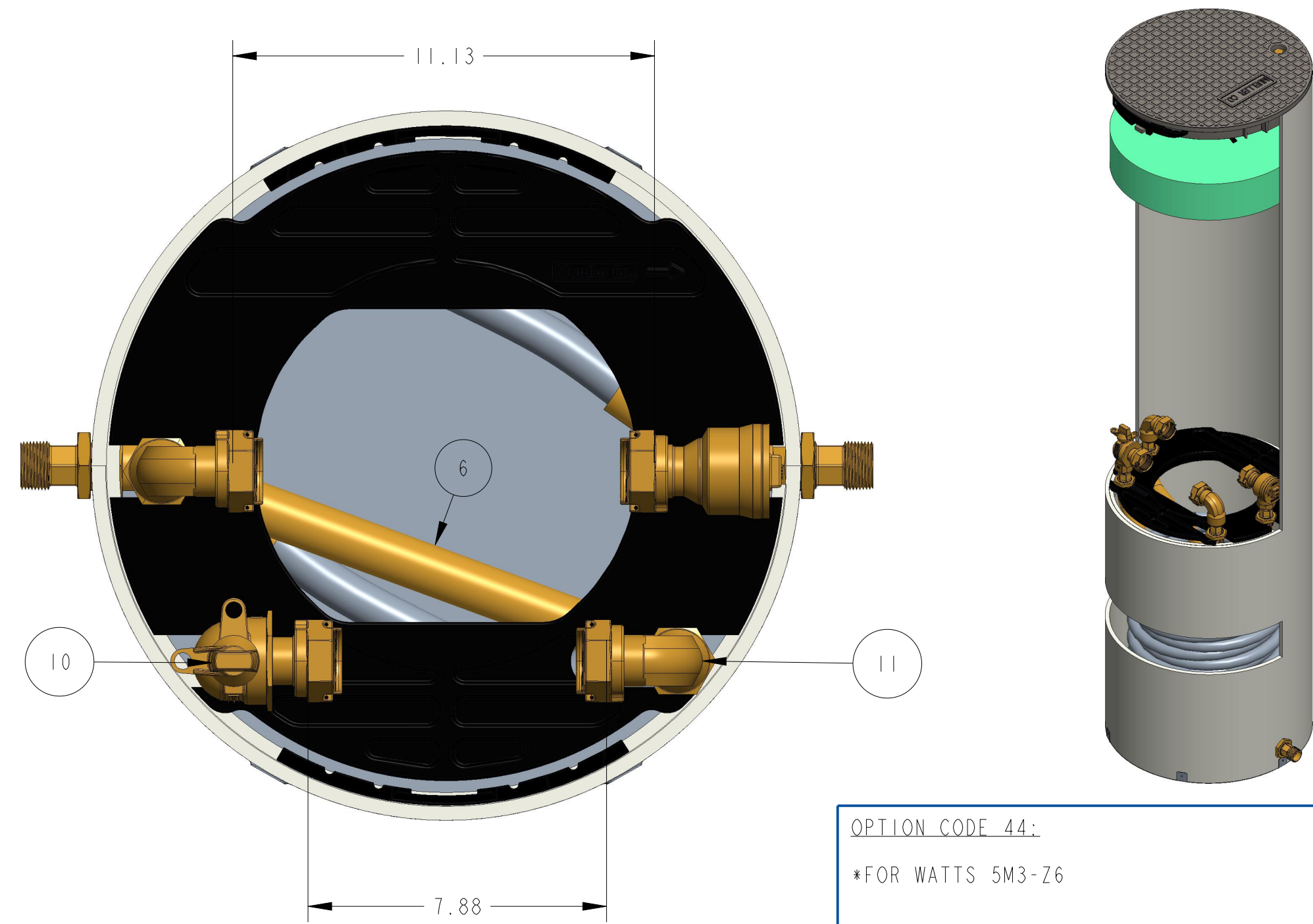

OPTION CODE 44:
*FOR WATTS 5M3-Z6

(B)
311980 WAS
311988
JBK 2/17/23

1" NPT THREADS
INLET AND OUTLET

DR. BY	AOD	6/14/22	UNLESS OTHERWISE NOTED	THIRD ANGLE PROJECTION		C.B. NO.
CHKR			BREAK CAST CORNER(S)---			
ENGR			BREAK MACH CORNER(S)---	PURCH.	FINISH	PATT. NO.
MGR			TOLERANCES	REF. NO.	SCALE	
MFG			UNLESS OTHERWISE NOTED	STR. NO.		
TOOL			LINEAR	ANGULAR		
FDRY			±	±		
MAT'L:			DESCR. 1" COIL TANDEM METER PIT 18" DIA X 72" DEPTH LOW LEAD BRASS		NUMBER 330CT1872FSAS000044N	
			MUELLER			