

330YS2440FVBN000587N

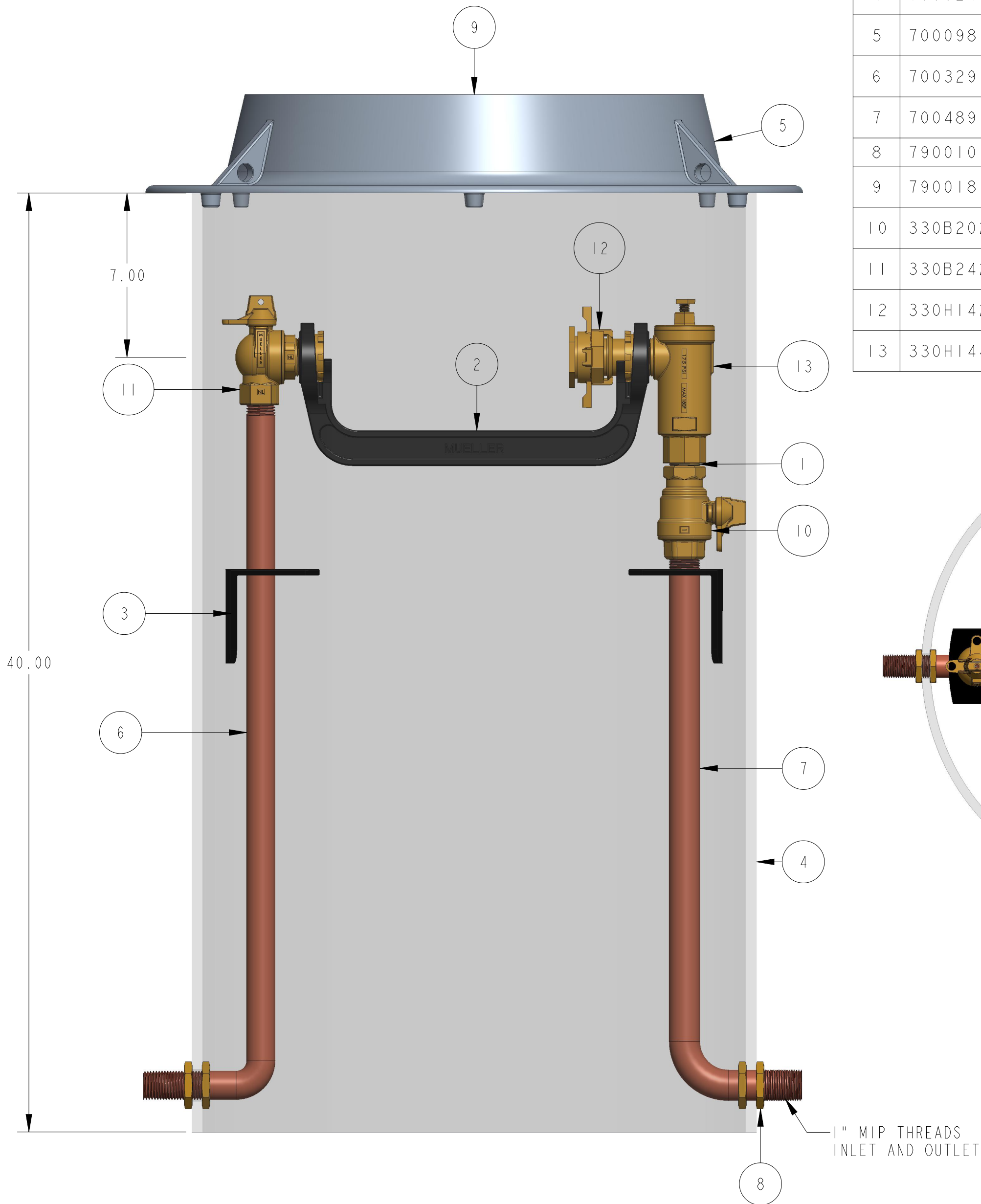

ITEM NO	PART NUMBER	QTY	DESCRIPTION	MATERIAL
1	047139	1	1" X 1-1/2" CLOSED NIPPLE	RED BRASS ASTM B43 ALLOY C23000 O61 TEMPER ANNEALED
2	526093-1	1	CAST IRON METER BAR	CAST IRON ASTM A126 CLASS B
3	546396	2	3/4" SUPPORT BRACKET	BLACK PLASTIC ABS
4	700024-2440	1	SHELL SUB-ASSEMBLY	SDR-51 PVC PIPE ASTM D2241 GRADE 1120
5	700098-1	1	CAST IRON FRAME (PURCHASED SEPARATELY)	CAST IRON ASTM A48 CLASS 25A
6	700329	1	RISER	RED BRASS ASTM B43 ALLOY C23000 O61 TEMPER ANNEALED
7	700489	1	1" RISER	RED BRASS ASTM B43 ALLOY C23000 O61 TEMPER ANNEALED
8	790010	4	1" HEX NUT	ASTM B16 ALLOY C36000
9	790018	1	18" NON LOCKING FLAT LID (SOLD SEPERATELY)	CAST IRON
10	330B20200N	1	1" INLINE BALL VALVE	LEAD FREE BRASS ALLOY ASTM B584 C89833/C87850
11	330B24278N	1	1" BALL ANGLE METER VALVE LLB	LEAD FREE BRASS ALLOY ASTM B584 C89833/C87850
12	330HI4234N	1	1" HANDWHEEL EXPANSION UNIT	LEAD FREE BRASS ALLOY ASTM B584 C89833/C87850
13	330HI446405AN	1	1" ANGLE CHECK W/ TEST VALVE LLB	LEAD FREE BRASS ALLOY ASTM B584 C89833/C87850

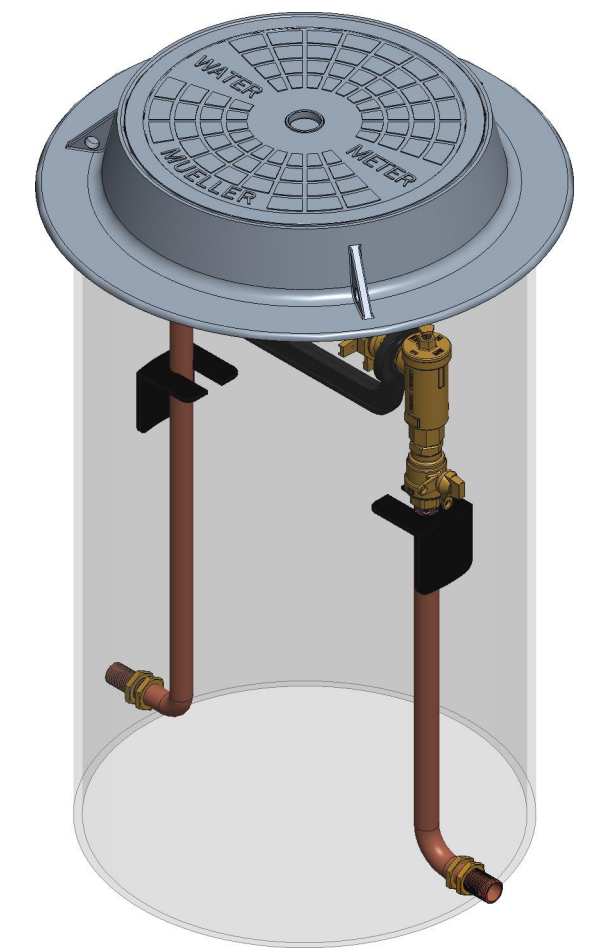
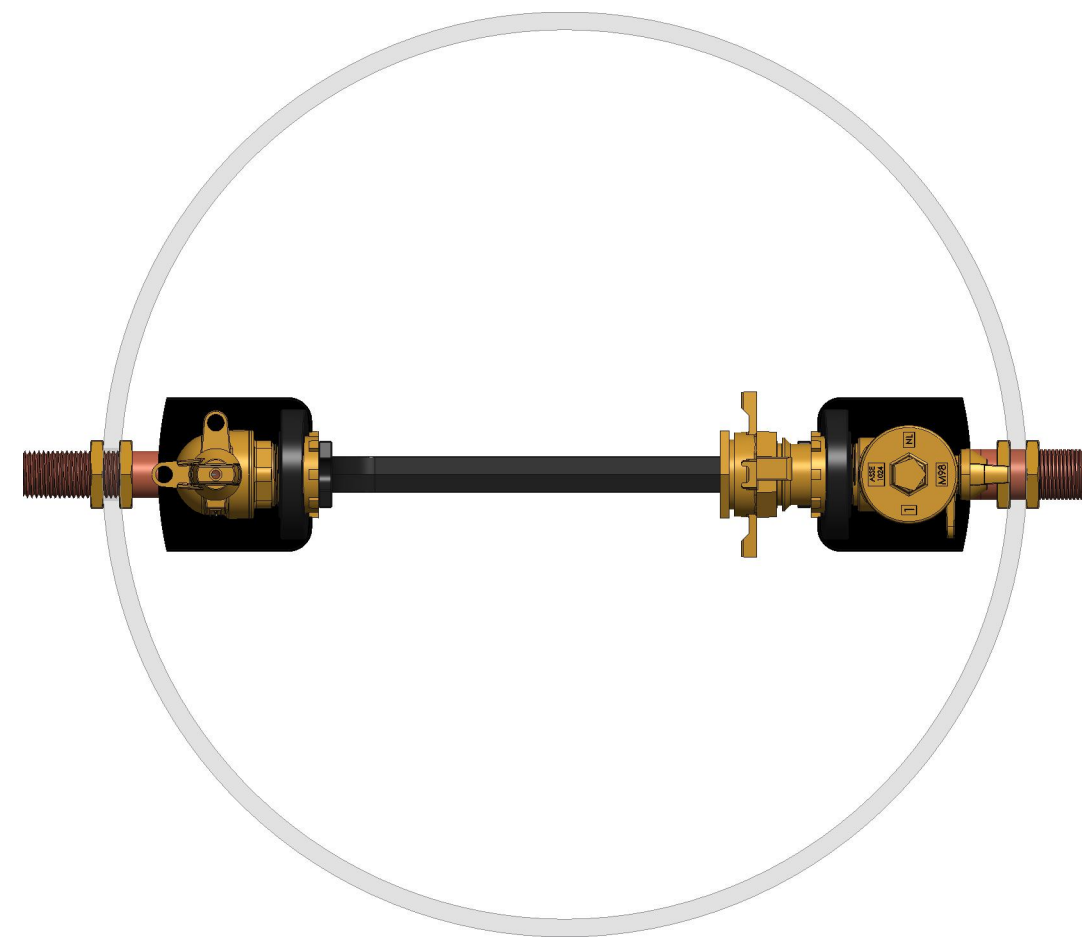

OPTION CODE 587:
 *WITH VERTICAL CHECK WITH TEST PORT AND B20200 UNDER OUTLET CHECK VALVE
 *CENTERLINE 7" FROM TOP OF SHELL

DR. BY	AOD	3/17/22	UNLESS OTHERWISE NOTED	THIRD ANGLE PROJECTION	C.B. NO.
CHKR			BREAK CAST CORNER(S)---		
ENGR			BREAK MACH CORNER(S)---	PURCH.	FINISH
MGR			TOLERANCES	REF. NO.	SCALE
MFG			UNLESS OTHERWISE NOTED	STR. NO.	
TOOL			LINEAR	ANGULAR	
FDRY			±	±	
MAT'L:					
MUELLER			DESCR. 1" YOKE SINGLE METER PIT 24" DIA X 40" DEPTH LOW LEAD BRASS		NUMBER 330YS2440FVBN000587N