

ITEM NO	PART NUMBER	QTY	DESCRIPTION	MATERIAL
1	047139	2	1" X 1-1/2" CLOSED NIPPLE	RED BRASS ASTM B43 ALLOY C23000 O61 TEMPER ANNEALED
2	282925	1	18" DIA CAST IRON SIDE LOCKING LID (SOLD SEPARATELY)	CAST IRON ASTM A126 CLASS B
3	546327	1	PIPE PART 17" LONG	RED BRASS ASTM B43 ALLOY C23000 HARD TEMPER
4	548555	2	STAINLESS STEEL SUPPORT BRACKET	304L STAINLESS STEEL
5	548556	2	BULKHEAD NIPPLE	RED BRASS ASTM B43 ALLOY C23000 HARD TEMPER
6	700005-2736	1	SHELL SUB ASSEMBLY	SDR-51 PVC PIPE ASTM D2241 GRADE 1120
7	700080	1	1" COPPER TUBE	HARD TEMPER COPPER TUBING
8	700098-1	1	CAST IRON FRAME (PURCHASED SEPARATELY)	CAST IRON ASTM A48 CLASS 25A
9	700327	1	PIPE PART 11-1/2" LONG	RED BRASS ASTM B43 ALLOY C23000 HARD TEMPER
10	790043	4	2" HEX NUT	ASTM B16 ALLOY C36000
11	790058	1	27" X 4" INSULATION PAD (PURCHASED SEPARATELY)	ETHAFOAM 220 WHITE OR POLYLAM 1.7 DENSITY WHITE
12	330B25170N	1	1" INLINE BALL VALVE (110 X FIP)	LEAD FREE BRASS ALLOY ASTM B584 C89833/C87850
13	330H14243AN	1	1" INLINE ASSE CHECK VALVE	LEAD FREE BRASS ALLOY ASTM B584 C89833/C87850
14	330H15428N	1	1" MIP X 1" CTS COMPRESSION TAILPIECE	LEAD FREE BRASS ALLOY ASTM B584 C89833/C87850
15	509688E	2	2" X 2" X 1" RISER TEE	LEAD FREE BRASS ALLOY ASTM B584 C89833/C87850
16	550B242860IN	1	2" FULL PORT BALL VALVE	LEAD FREE BRASS ALLOY ASTM B584 C89833/C87850
17	550H14660AN	1	2" ASSE APPROVED VERTICAL CHECK VALVE	LEAD FREE BRASS ALLOY ASTM B584 C89833/C87850

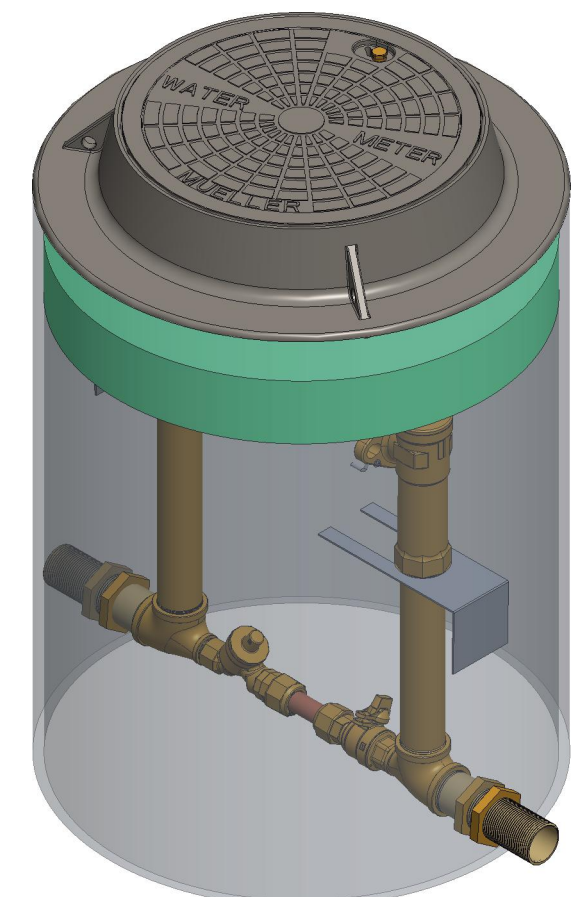
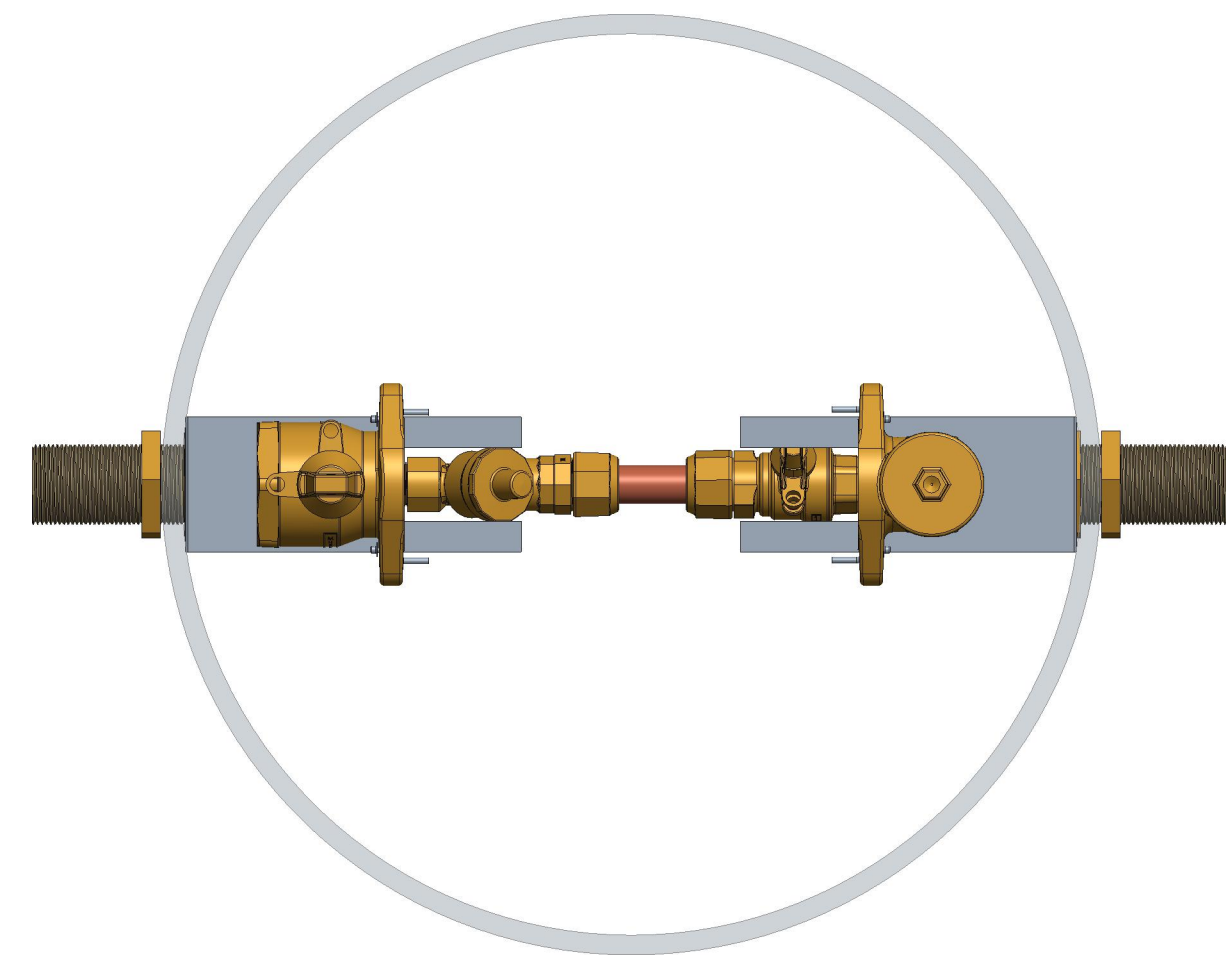
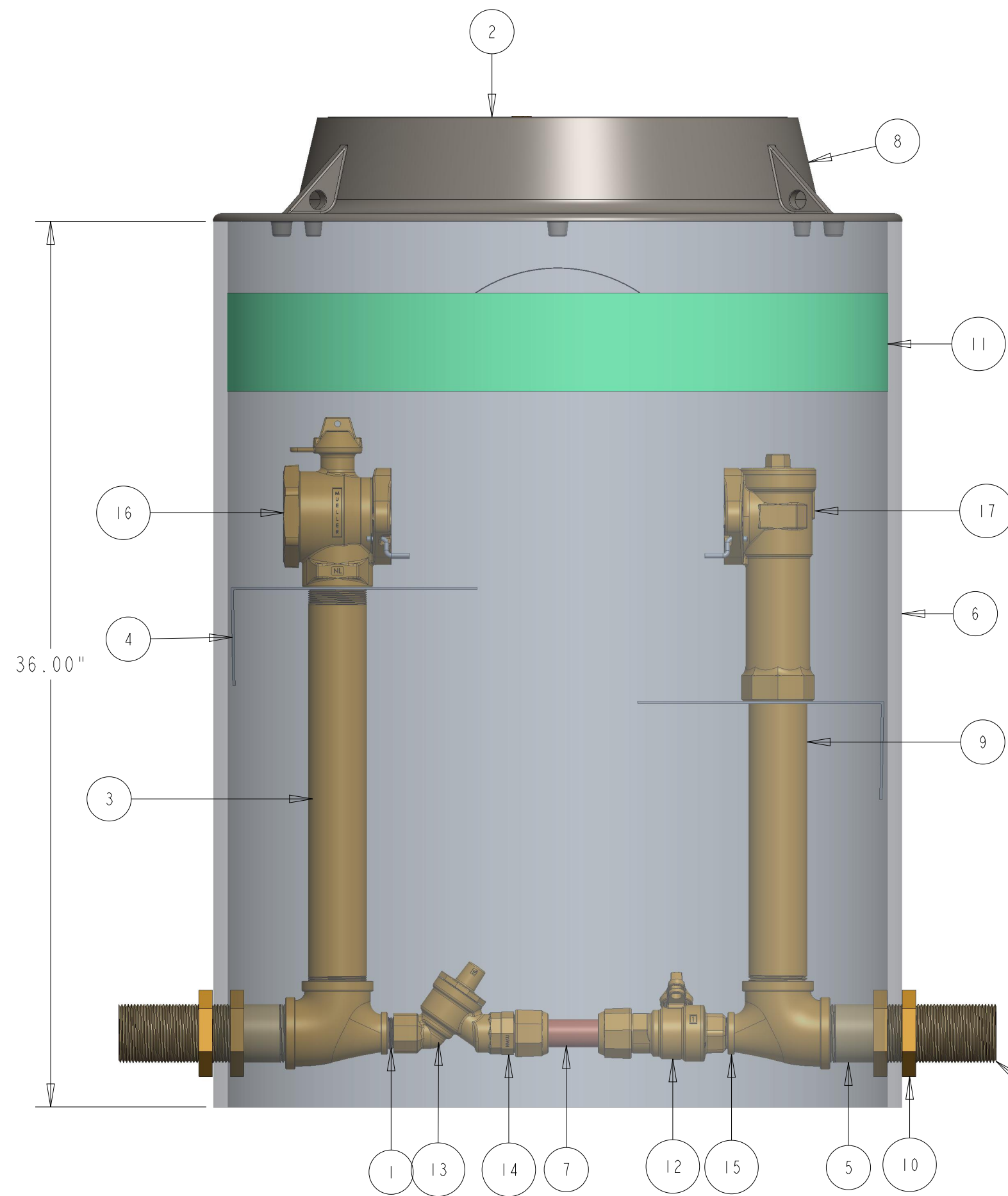

2" MNPT THREADS INLET & OUTLET

OPTION CODE 312:
-FOR 1" BYPASS WITH 1" ASSE APPROVED CHECK VALVE

DR. BY	DWS	02/12/19	UNLESS OTHERWISE NOTED	THIRD ANGLE PROJECTION	C.B. NO.
CHKR			BREAK CAST CORNER(S)---		
ENGR			BREAK MACH CORNER(S)---	PURCH.	FINISH
MGR			TOLERANCES	REF. NO.	SCALE
MFG			UNLESS OTHERWISE NOTED	STR. NO.	
TOOL			LINEAR	ANGULAR	
FDRY			±	±	
MAT'L:					
MUELLER			DESCR. 2" VAULT BY-PASS METER PIT 27" DIA X 36" DEPTH LEAD FREE BRASS		NUMBER 550VB2736FVB000312N