

550VB3636FVBN

ITEM NO	PART NUMBER	QTY	DESCRIPTION	MATERIAL
1	047141	1	1-1/2" CLOSED NIPPLE	RED BRASS ASTM B43 ALLOY C23000 HARD TEMPER
2	548255	1	THREADED PIPE 2" X 13-1/2"	RED BRASS ASTM B43 ALLOY C23000 HARD TEMPER
3	548555	2	STAINLESS STEEL SUPPORT BRACKET	304L STAINLESS STEEL
4	548556	2	BULKHEAD NIPPLE	RED BRASS ASTM B43 ALLOY C23000 HARD TEMPER
5	552192	1	THREADED PIPE 2" X 15-1/2"	RED BRASS ASTM B43 ALLOY C23000 HARD TEMPER
6	700047	1	COPPER TUBING	COPPER TUBING ASTM B75 UNS C12200, H80 TEMPER
7	780113	1	18" DIA CAST IRON LID W/ RECESSED TR (SOLD SEPARATELY)	CAST IRON ASTM A125 CLASS B AND CAST BRONZE ASTM B584/B62 ALLOY C84400/C83600
8	790043	4	2" HEX NUT	ASTM B16 ALLOY C36000
9	790244	1	36" x 36" SHELL	POLYETHYLENE 0036-36 B BODY B-W 2 M <sub>s</sub> HI
10	790438	1	36" EXTENSION RING W/ 18" OPENING (SOLD SEPERATELY)	CAST IRON ASTM A48 CLASS 25A AND 0.375" A36 CARBON STEEL
11	500H1517201N	1	1-1/2" ORISEAL VALVE	LEAD FREE BRASS ALLOY ASTM B584 C89833/C87850
12	500H15428N	1	1-1/2" 110 COMP X MIP TAILPIECE	LEAD FREE BRASS ALLOY ASTM B584 C89833/C87850
13	550B2428601N	1	2" FULL PORT BALL VALVE	LEAD FREE BRASS ALLOY ASTM B584 C89833/C87850
14	550H14660AN	1	2" ASSE APPROVED VERTICAL CHECK VALVE	LEAD FREE BRASS ALLOY ASTM B584 C89833/C87850
15	790051E	2	2" X 2" X 1-1/2" TEE	ASTM B584 ALLOY C89520 OR C89833

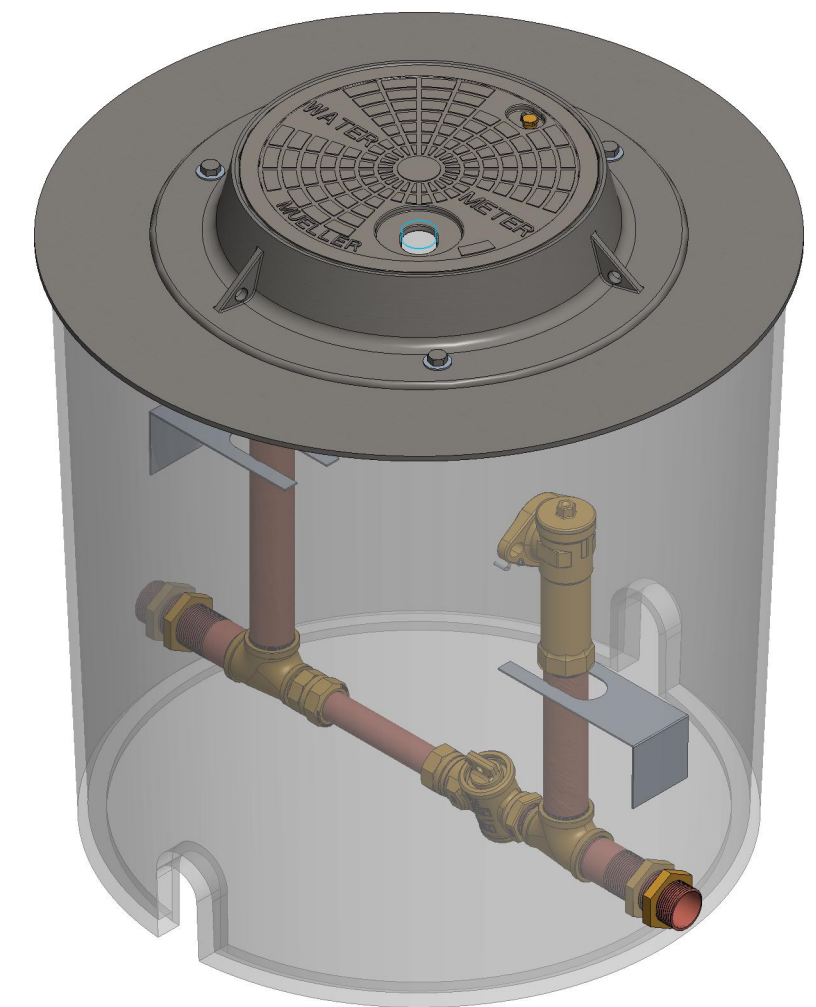
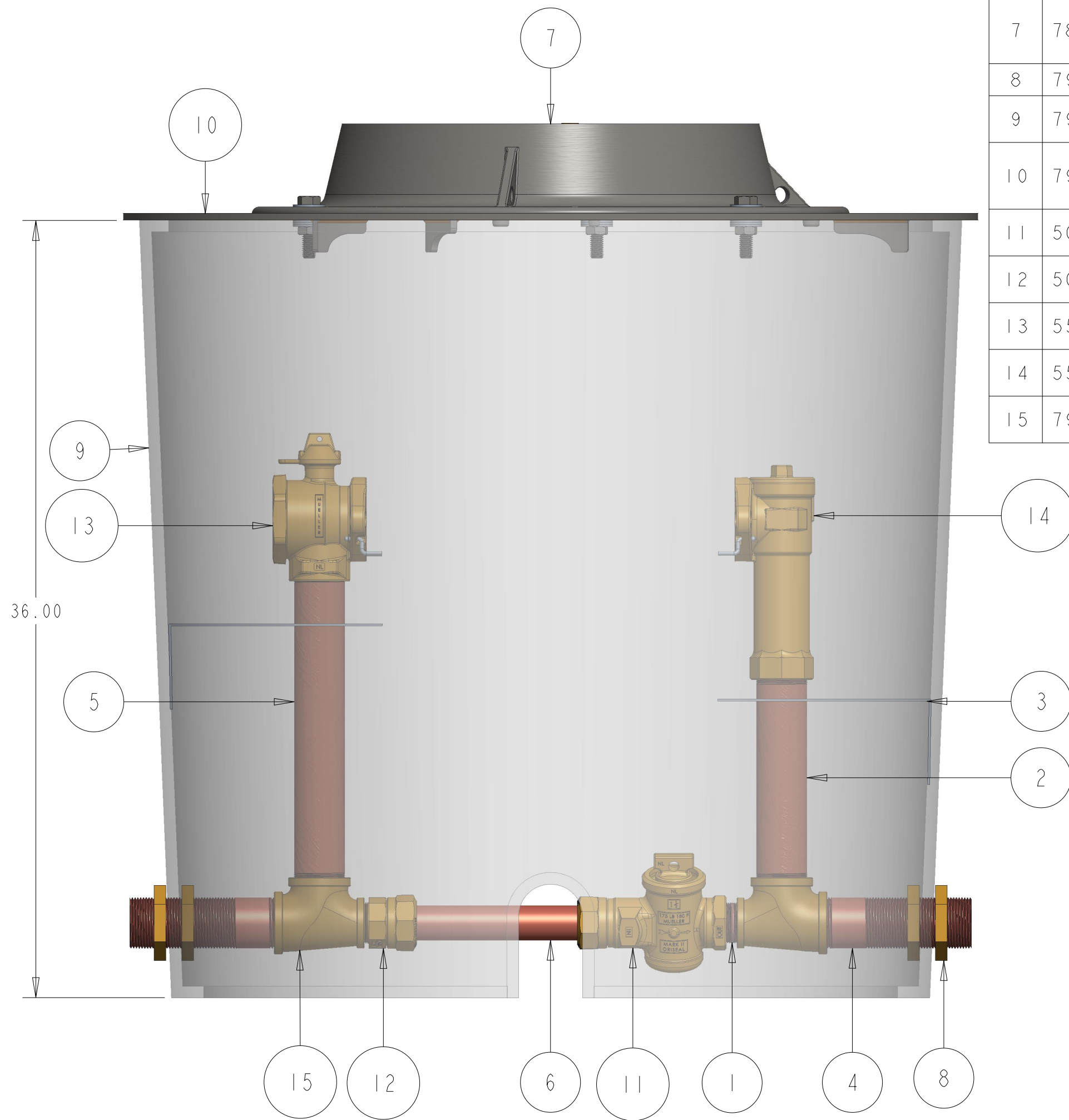

Ⓑ  
CHANGED RISERS TO 552192  
AND 548255  
AOD  
5/09/2023

DR. BY	BBF	4/25/18	UNLESS OTHERWISE NOTED	THIRD ANGLE PROJECTION	C.B. NO.
CHKR			BREAK CAST CORNER(S)---		
ENGR			BREAK MACH CORNER(S)---	PURCH.	FINISH
MGR			TOLERANCES	REF. NO.	SCALE
MFG			UNLESS OTHERWISE NOTED	STR. NO.	
TOOL			LINEAR	ANGULAR	
FDRY			±	±	
MAT'L:					
<b>MUELLER</b>			DESCR.	NUMBER	
			2" VAULT BY-PASS 36"DIA X 36" DEPTH LEAD FREE BRASS	550VB3636FVBN	