

550VB3636LLBN

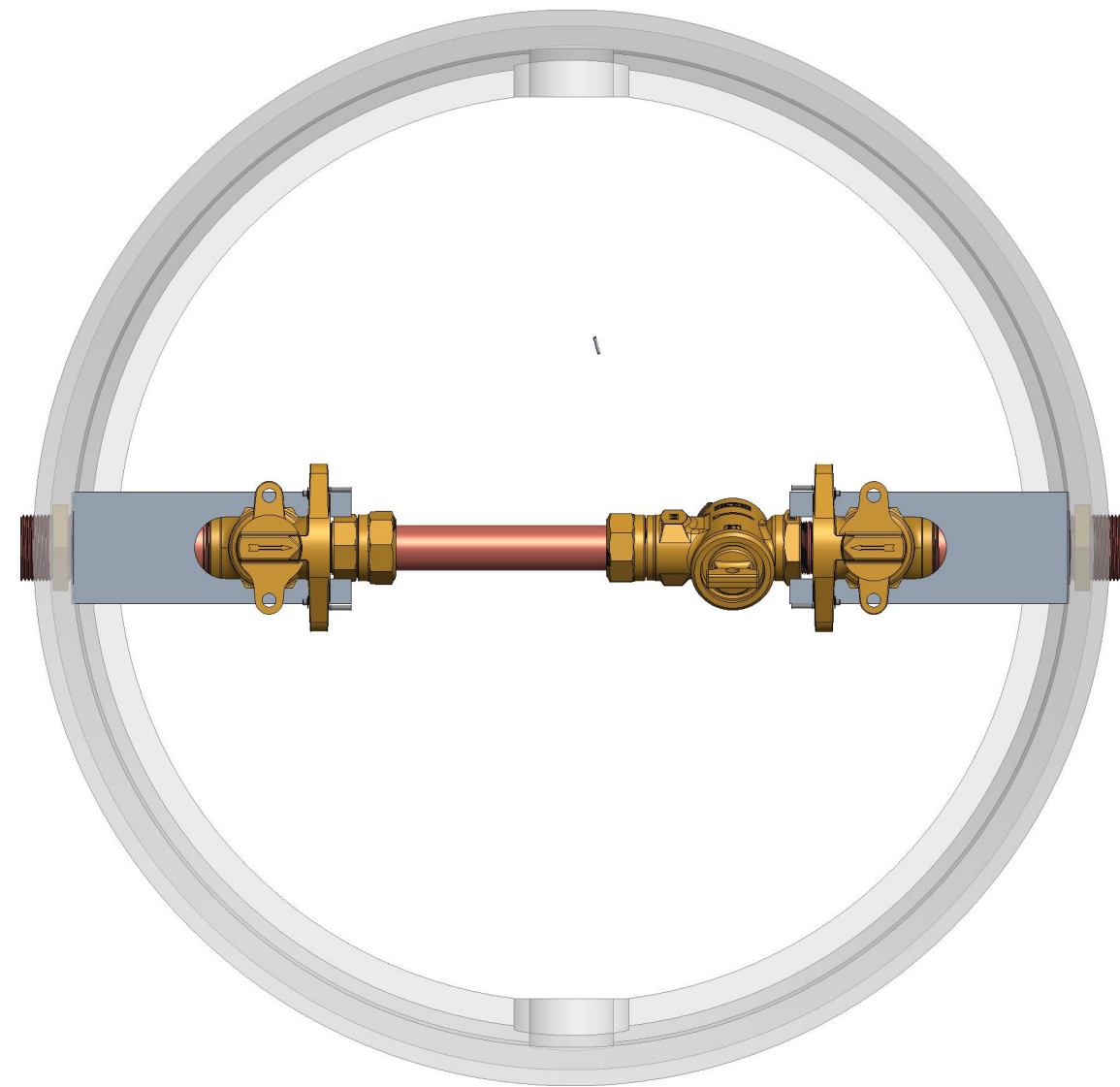

ITEM NO	PART NUMBER	QTY	DESCRIPTION	MATERIAL
1	047141	1	1-1/2" CLOSED NIPPLE	RED BRASS ASTM B43 ALLOY C23000 HARD TEMPER
2	547049	2	2" THREADED PIPE	RED BRASS ASTM B43 ALLOY C23000 HARD TEMPER
3	548555	2	STAINLESS STEEL SUPPORT BRACKET	304L STAINLESS STEEL
4	548556	2	BULKHEAD NIPPLE	RED BRASS ASTM B43 ALLOY C23000 HARD TEMPER
5	700047	1	COPPER TUBING	COPPER TUBING ASTM B75 UNS C12200, H80 TEMPER
6	780113	1	18" DIA CAST IRON LID W/ RECESSED TR (SOLD SEPARATELY)	CAST IRON ASTM A125 CLASS B AND CAST BRONZE ASTM B584/B62 ALLOY C84400/C83600
7	790043	4	2" HEX NUT	ASTM B16 ALLOY C36000
8	790244	1	36" x 36" SHELL	POLYETHYLENE 0036-36 B BODY B-W 2 MSHI
9	790438	1	36" EXTENSION RING W/ 18" OPENING (SOLD SEPERATELY)	CAST IRON ASTM A48 CLASS 25A AND 0.375" A36 CARBON STEEL
10	500HI51720IN	1	1-1/2" ORISEAL VALVE	LEAD FREE BRASS ALLOY ASTM B584 C89833/C87850
11	500HI5428N	1	1-1/2" 110 COMP X MIP TAILPIECE	LEAD FREE BRASS ALLOY ASTM B584 C89833/C87850
12	550HI42860IN	2	2" ANGLE METER STOP	LEAD FREE BRASS ALLOY ASTM B584 C89833/C87850
13	790051E	2	2" X 2" X 1-1/2" TEE	ASTM B584 ALLOY C89520 OR C89833

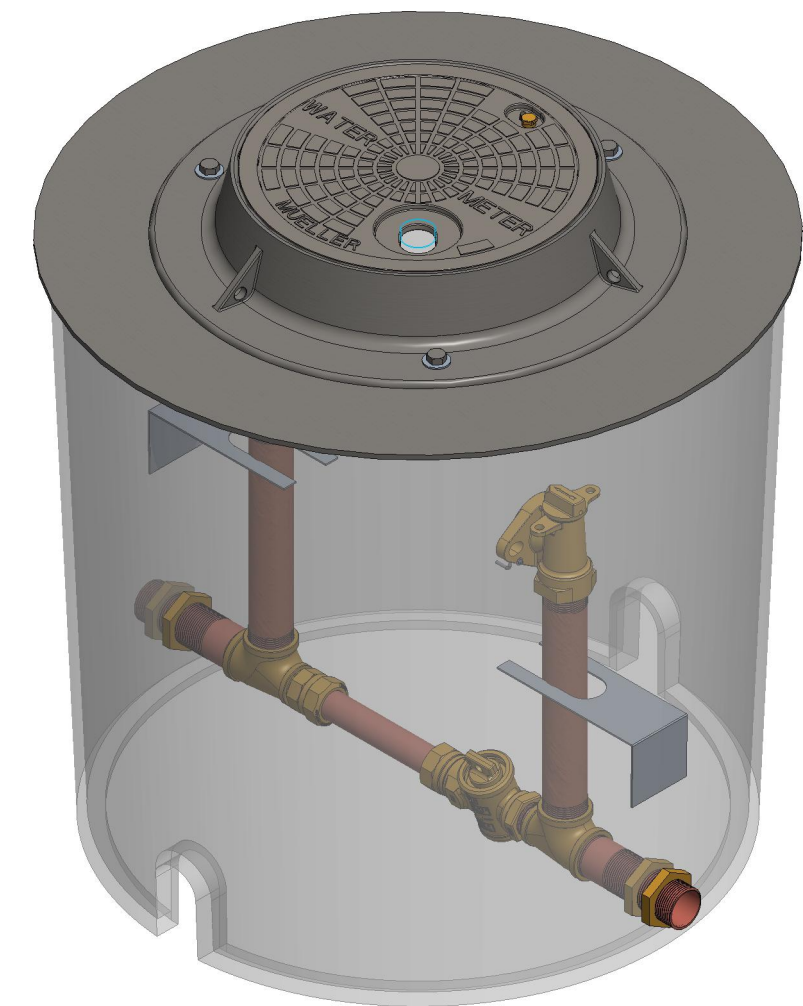
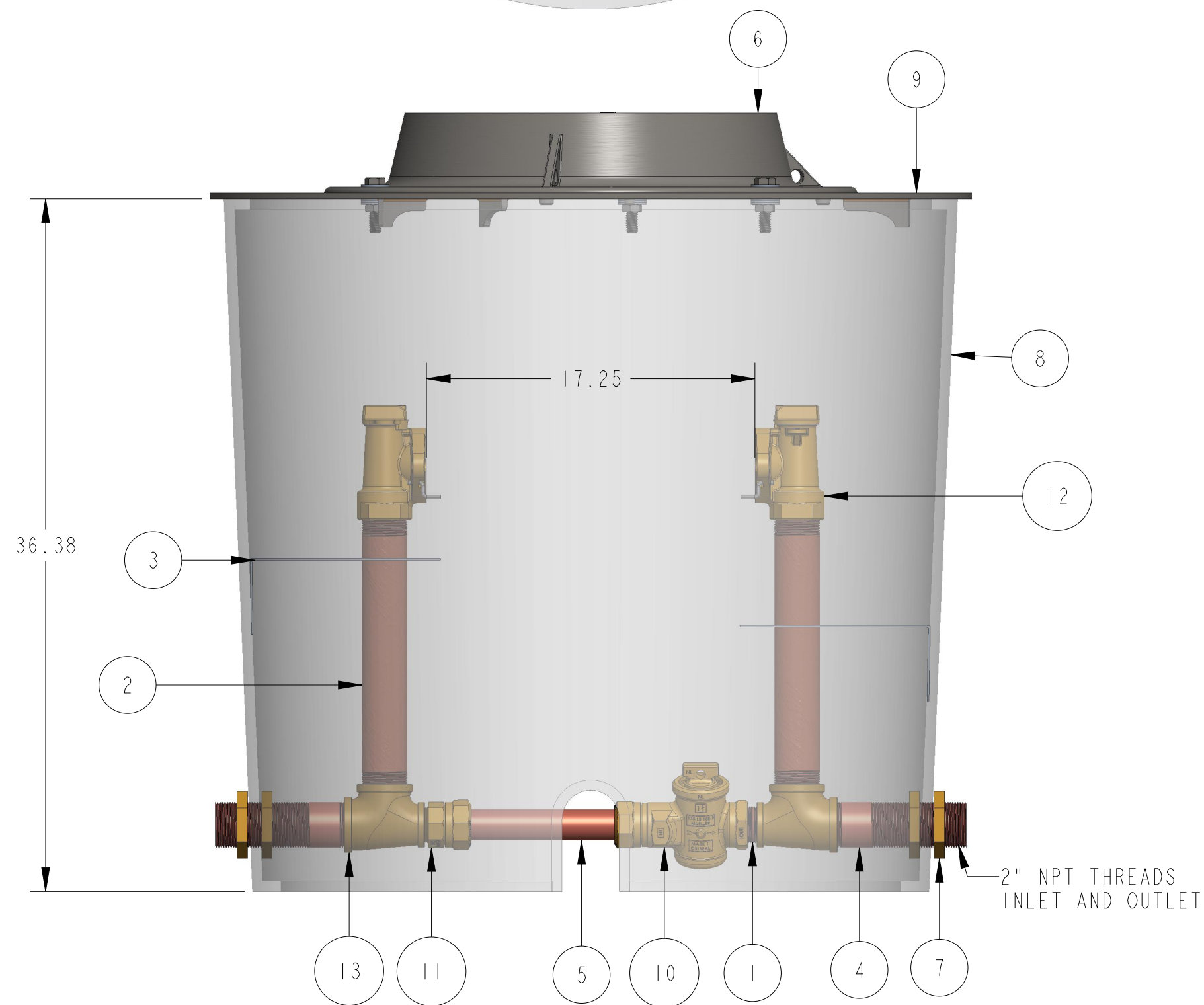

Ⓑ
CHANGED LAY LENGTH FROM
15-1/4" TO 17-1/4"
1/12/22
AOD

DR. BY	AOD	1/06/22	UNLESS OTHERWISE NOTED	THIRD ANGLE PROJECTION	C.B. NO.
CHKR			BREAK CAST CORNER(S)---		
ENGR			BREAK MACH CORNER(S)---	PURCH.	FINISH
MGR			TOLERANCES	REF. NO.	SCALE
MFG			UNLESS OTHERWISE NOTED	STR. NO.	
TOOL			LINEAR		
FDRY			±		
MAT'L:					
MUELLER			DESCR. 2" VAULT BYPASS METER PIT 36" DIA X 36" DEPTH LEAD FREE BRASS	NUMBER 550VB3636LLBN	