

550VT3660FFB000447N

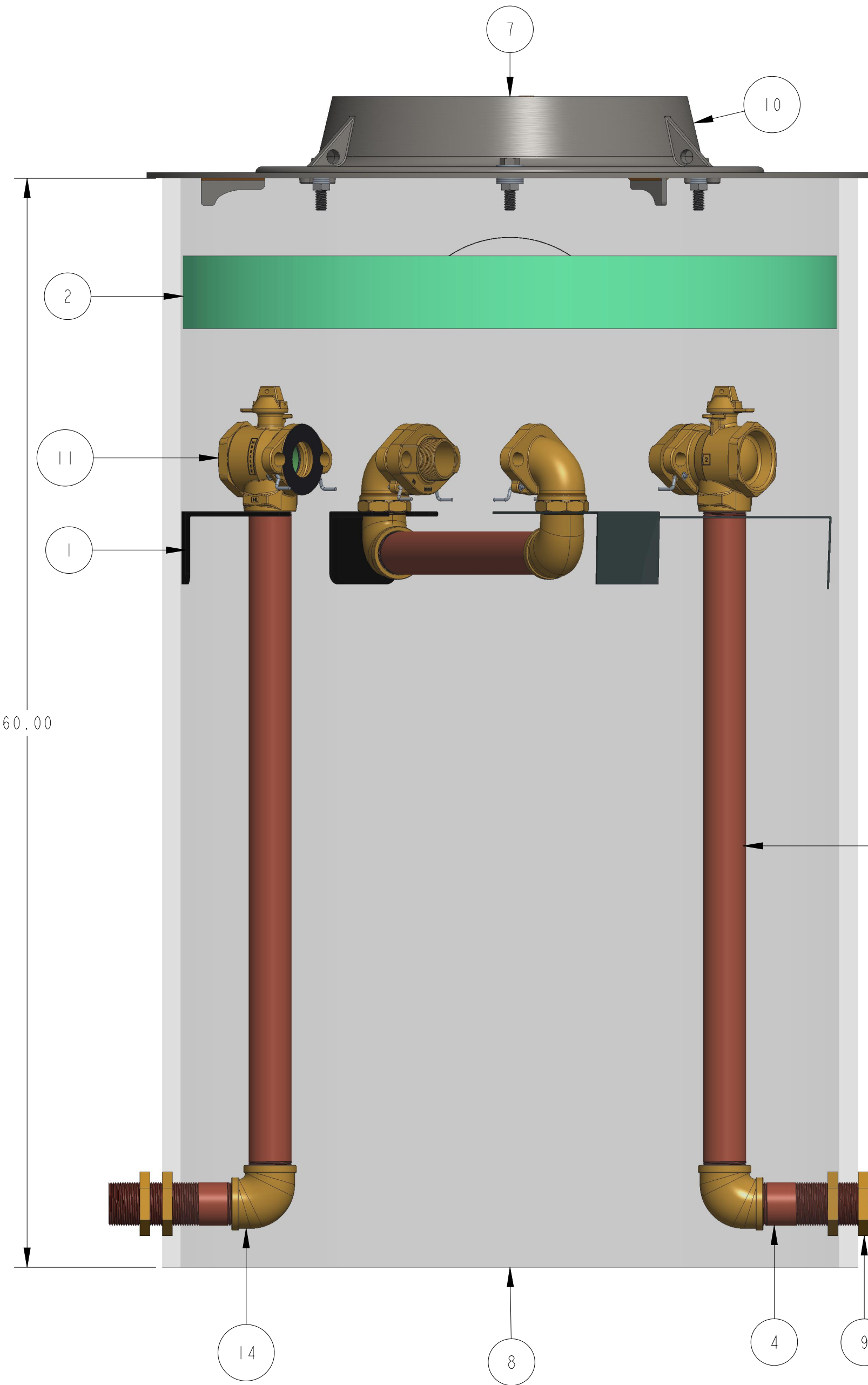

ITEM NO	PART NUMBER	QTY	DESCRIPTION	MATERIAL
1	547405	2	SUPPORT BRACKET	BLACK PLASTIC ABS
2	547743	1	36" INSULATION PAD (SOLD SEPERATELY)	ETHAFOAM 220 WHITE OR POLYLAM 1.7 DENSITY WHITE
3	548554	2	STAINLESS STEEL SUPPORT BRACKET	12 GAUGE STAINLESS STEEL
4	548556	2	BULKHEAD NIPPLE	RED BRASS ASTM B43 ALLOY C23000 HARD TEMPER
5	551988	1	THREADED PIPE	RED BRASS ASTM B43 ALLOY C23000 HARD TEMPER
6	700079	2	2" THREADED PIPE	RED BRASS ASTM B43 ALLOY C23000 HARD TEMPER
7	780113	1	18" DIA CAST IRON LID W/ RECESSED TR (SOLD SEPARATELY)	CAST IRON ASTM A125 CLASS B AND CAST BRONZE ASTM B584/B62 ALLOY C84400/C83600
8	780181-3660	1	SHELL SUB ASSEMBLY	SDR-32.5 BLACK POLYETHENE PIPE ASTM D2241 IPS
9	790043	4	2" HEX NUT	ASTM B16 ALLOY C36000
10	790438	1	36" EXTENSION RING W/ 18" OPENING (SOLD SEPERATELY)	CAST IRON ASTM A48 CLASS 25A AND 0.375" A36 CARBON STEEL
11	550B2428601N	2	2" FULL PORT BALL VALVE	LEAD FREE BRASS ALLOY ASTM B584 C89833/C87850
12	550H10129MN	2	2" MALE METER FLANGE	LEAD FREE BRASS ALLOY ASTM B584 C89833/C87850
13	550H14204N	2	2" METER COUPLING	LEAD FREE BRASS ALLOY ASTM B584 C89833/C87850
14	790041E	2	ELBOW	CAST BRONZE ASTM B584 ALLOY C89833
15	790047E	2	2" STREET ELBOW	CAST BRONZE ASTM B584 ALLOY C89833

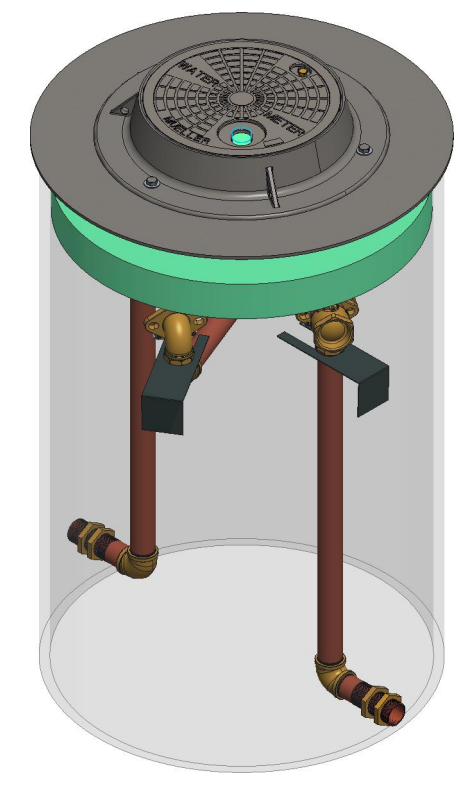
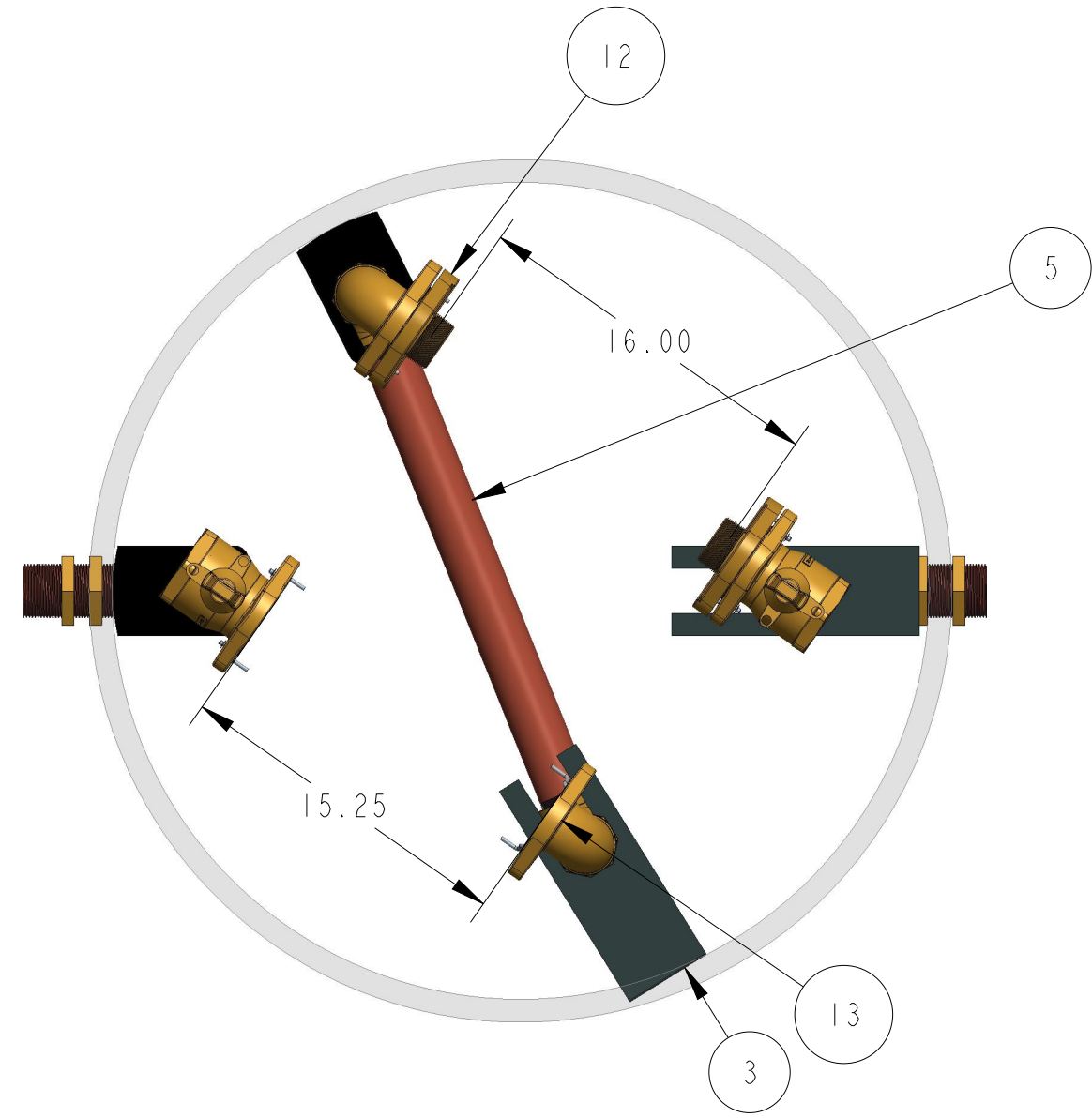

OPTION CODE 447:  
 \*TANDEM FOR WILKINS 350XL DOUBLE CHECK  
 \*ADD SPUDS

DR. BY	AOD	5/20/22	UNLESS OTHERWISE NOTED	THIRD ANGLE PROJECTION	C.B. NO.
CHKR			BREAK CAST CORNER(S)---		
ENGR			BREAK MACH CORNER(S)---	PURCH.	FINISH
MGR			TOLERANCES	REF. NO.	PATT. NO.
MFG			UNLESS OTHERWISE NOTED	SCALE	
TOOL			LINEAR	ANGULAR	STR. NO.
FDRY			±	±	
MAT'L:					

**MUELLER** DESCR. 2" VAULT TANDEM METER PIT 36" DIA X 60" DEPTH LEAD FREE BRASS NUMBER 550VT3660FFB000447N