

DWG. NO. 780112

REV.	DESCRIPTION	REF.	DRFTN	CHKR	APP	DATE
A	REDRAWN IN CAD	E.O. 2133	MWS	CJD	JMG	10-18-04
B	RECESS MODIFIED	E.O. 2195	SMC	CJD	JMG	9-29-05

ITEM	DESCRIPTION	PART NO	REQ'D
1	LID	700177	1
2	PENTAGON KEY	146323	1
3	PENTAGON KEY PIN	146324	1
4	LID LATCH	146306-1	1
5	LID LATCH SPRING	508558	1
6	LID LATCH RIVET	790146	1

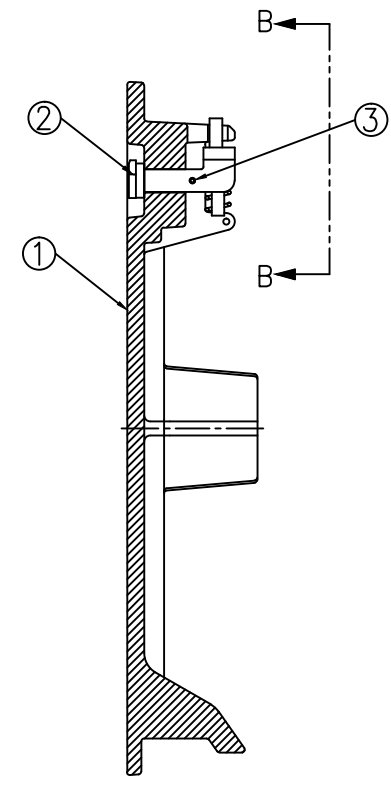
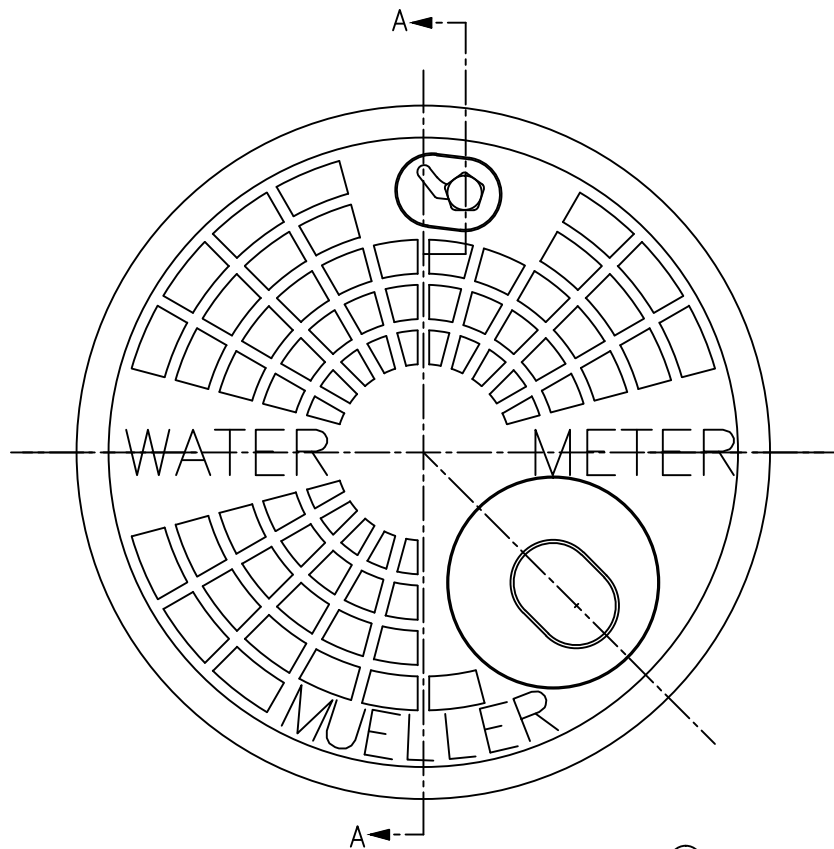

SECTION A-A

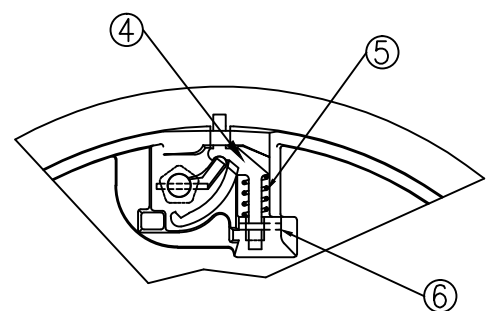

VIEW B-B

A/C (MILLIMETER)		TOLERANCES - MACHINING		THIRD ANGLE PROJECTION	
INCH		UNLESS OTHERWISE NOTED			
INITIAL RELEASE		BREAK EDGES		PUNCH	
DRFTN MWS 10-18-04		MACH. .006/.016		FINISH	
CHKR CJD 10-18-04		125		REF. NO.	
APP JMG 10-18-04		FRACTIONS		SCALE	
E.O. NUMBER 2133		±1/64		1:2	
MATERIAL		DECIMALS		STK. NO.	
DESCR.		2 PL ±.025		REVISION	
Mueller Co.		3 PL ±.010		B	
15" METER BOX LID WITH PENTAGON KEY		ANGLES ±1°		NUMBER	
				780112	
				SHEET 1 OF 1	