

No.	DESCRIPTION	MATERIAL
1	STEM	LOW LEAD BRASS ALLOY
2	O-RING	EPDM D2000
3	BALL	LOW LEAD BRASS ALLOY
4	GASKET - SEAL	NITRILE D2000
5	BODY	CAST LOW LEAD BRASS ALLOY
6	O-RING	EPDM D2000
7	END PIECE	CAST LOW LEAD BRASS ALLOY

SIZE	ØA	B	C	D	E
3/4	.750	3.955	.840	1.390	2.203
1	1.000	4.588	1.150	1.591	2.714
1-1/2	1.500	5.395	1.500	2.235	3.735
2	2.000	6.246	1.820	2.557	4.377

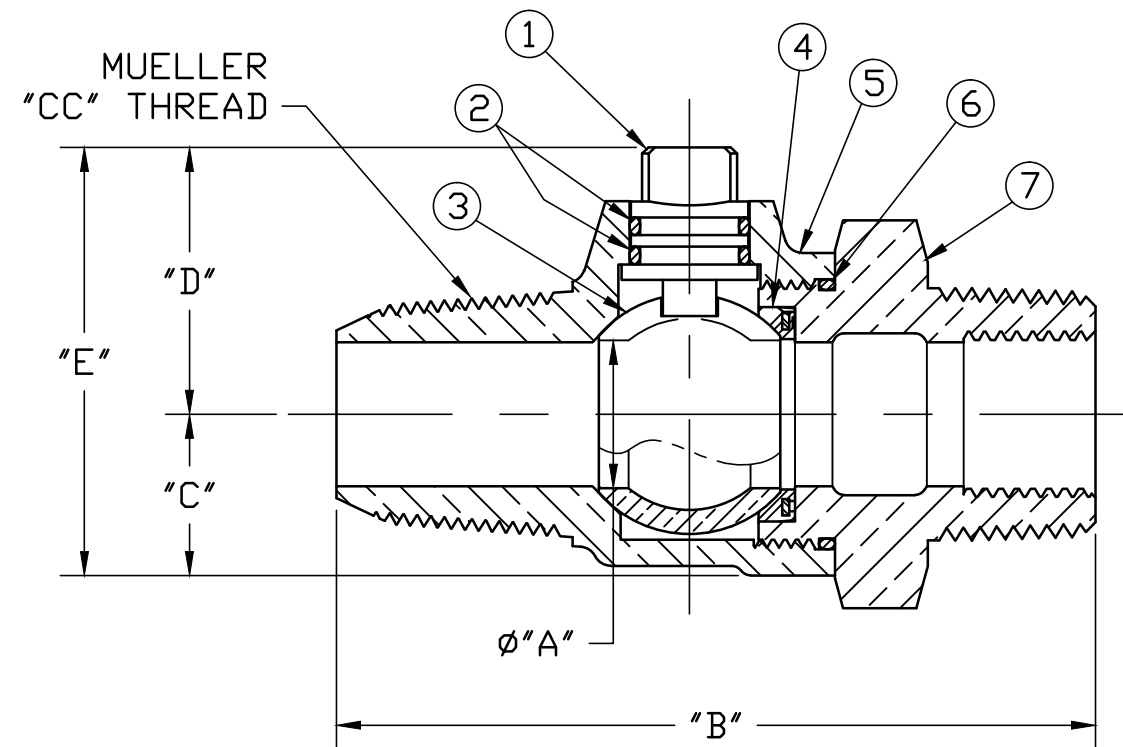

ALL WETTED PARTS ARE LOW LEAD BRASS ALLOY

FILEPATH: PROD-ENG\MUELLER\ASYSUBMITTALS\B20003N

						DRFTR	RWB	9/26/13	Mueller Co.	THIRD ANGLE PROJECTION
						CHKR				
						ENGR				
						MGR				
									UNLESS OTHERWISE NOTED	REF. No. SCALE NONE
									SURFACE PREPARATION:	
									BREAK CORNER(S) ---- .000 SURFACE FINISH -- 000 RMS	
									TOLERANCE(S):	
									LINEAR ----- ± .000	
									ANGULAR ----- ± 0°00'	
									STK No:	
									MAT'L:	
									DESCR.	DWG NUMBER
									MUELLER LLB CORP. STOP	B20003N
									BALL VALVE ("CC" x INC. IP)	
									PER EST NO: DXXXX	EST FIN WT = 0.0000 lbs

DWG NUMBER
B20003N
442-MRKTNG

TITLE TO AND OWNERSHIP OF THIS ENGINEERING DATA REMAINS IN Mueller Co. NO USE IS TO BE MADE OF THIS DATA EXCEPT AS SPECIFICALLY AUTHORIZED BY Mueller Co. ASSENT ON THE PART OF THE RECIPIENT TO THESE CONDITIONS IS PRESUMED