

No.	DESCRIPTION	MATERIAL DESCRIPTION
1	BODY	LEAD FREE BRASS ALLOY ASTM B584
2	CAP	CAST BRASS ALLOY ASTM B584
3	STEM	LEAD FREE BRASS ALLOY ASTM B584/B371
4	BALL	LEAD FREE BRASS ALLOY ASTM B584
5	GASKET	EPDM D2000
6	SCREW	18-8 STAINLESS STEEL
7	O-RING	EPDM D2000
8	END PIECE	LEAD FREE BRASS ALLOY ASTM B584
9	O-RING	EPDM D2000
10	CTS GASKET SUB	ASTM D2000(SBR)&410 STAINLESS STEEL
11	CONNX NUT	CAST BRASS ASTM B62 ALLOY C83600

SIZE	ØA	B	C	D	E
3/4"R	.63	3.21	.75	2.12	2.87
3/4"	.75	3.34	.84	2.32	3.16
3/4x1"	.75	3.59	.84	2.32	3.16
1"R	.75	3.77	.84	2.32	3.16
1"	1.00	4.51	1.15	2.57	3.72
1x3/4"R	.75	3.54	.84	2.32	3.16
1-1/2"	1.50	4.69	1.50	3.36	4.86
2"	2.00	5.24	1.82	3.91	5.73

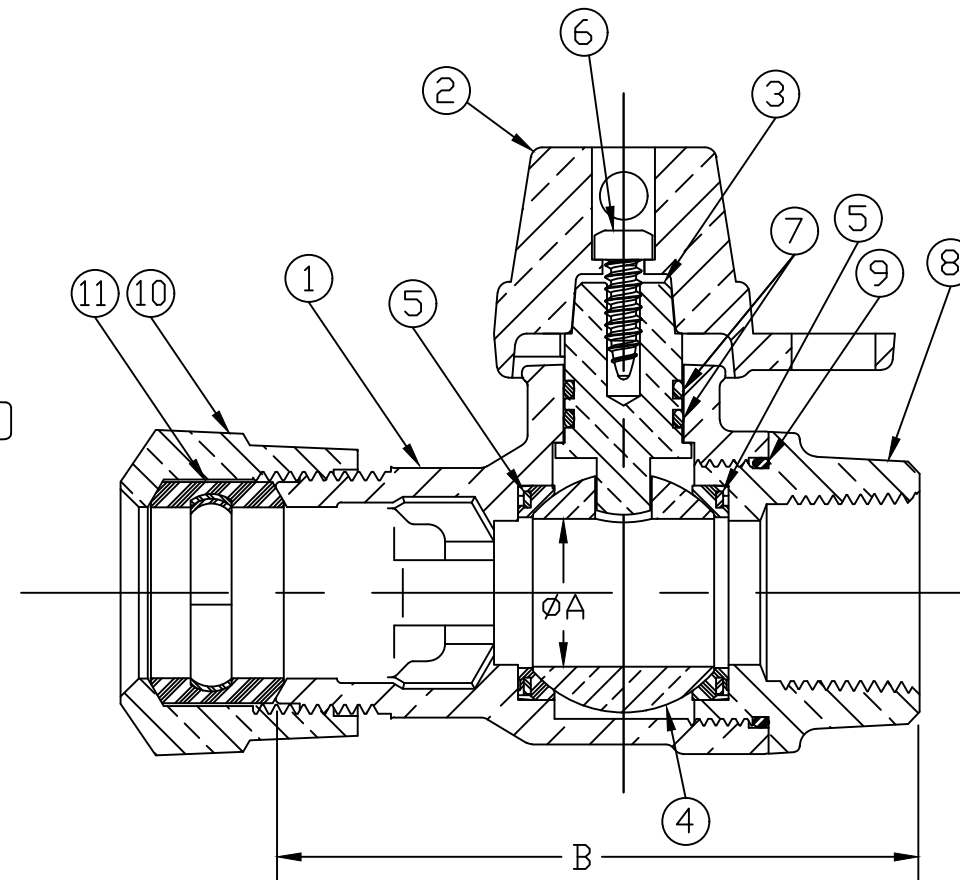
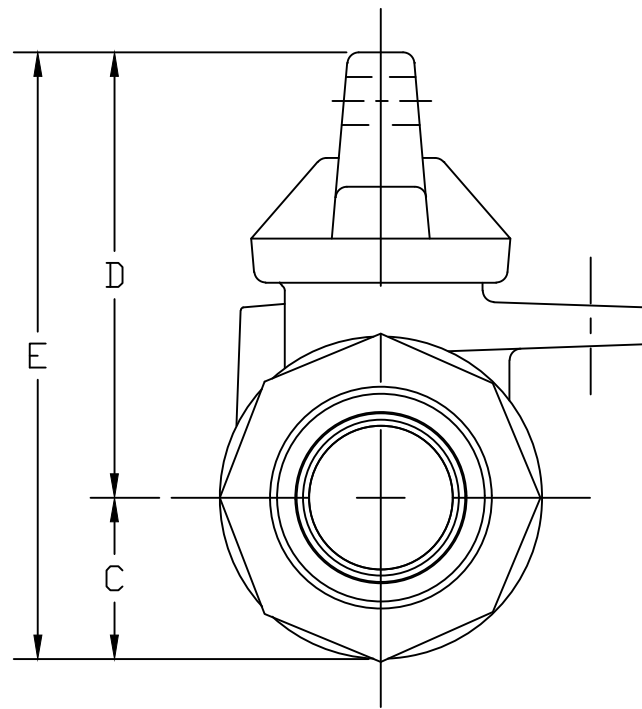

MEETS ALL REQUIREMENTS OF AWWA C800
 ALL STEMS ARE LEAD FREE BRASS ALLOY C89833/C69300
 ALL WETTED PARTS ARE LEAD FREE BRASS ALLOY C89833/C87850
 ALL NON WETTED PARTS ARE BRASS ALLOY C83600/C87850

DWG NUMBER
B25170N

TITLE TO AND OWNERSHIP OF THIS ENGINEERING
 DATA REMAINS IN Mueller Co. NO USE IS TO BE
 MADE OF THIS DATA EXCEPT AS SPECIFICALLY
 AUTHORIZED BY Mueller Co. ASSENT ON THE PART
 OF THE RECIPIENT TO THESE CONDITIONS IS PRESUMED

DRFTR	JGarvin	12/19/08	MUELLER	
CHKR				
ENGR			UNLESS OTHERWISE NOTED SURFACE PREPARATION: BREAK CORNER(S) ---- .000 SURFACE FINISH --XXX RMS	THIRD ANGLE PROJECTION
MGR				TOLERANCE(S): LINEAR ----- ± .000 ANGULAR ----- ± 0°00'
	BY	DATE		SCALE
				FULL
STK No:				
MAT'L:				
DESCR.			DWG NUMBER	
INLINE BALL METER VALVE (110 CTS x FIP)			B25170N	