

ISSUE #	DATE	CHANGE DESCRIPTION	BY	AP
01	09/14/17	ADDED SEAT CODE TO TYPE	ALA	
02	04/27/18	UPDATE REF, TYPE, & UN-VOIDED	DCC	SS
03	05/22/18	REMOVED MARKING	DJK	JL
04	12/11/19	ADDED WEIGHTS & FLOW, UPDATED TITLE	AJM	AM

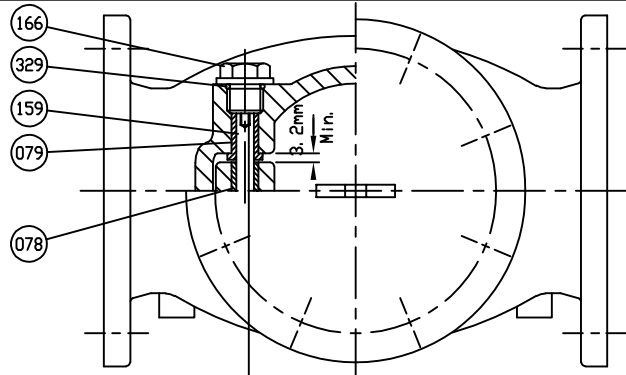

DETAIL A FOR TAG PLATE

Remark - Flanged connection : Other Standards are also available.



Drilled and threaded hole in each end of the hinge pin

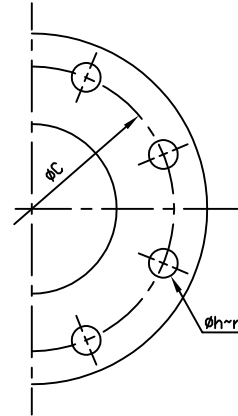
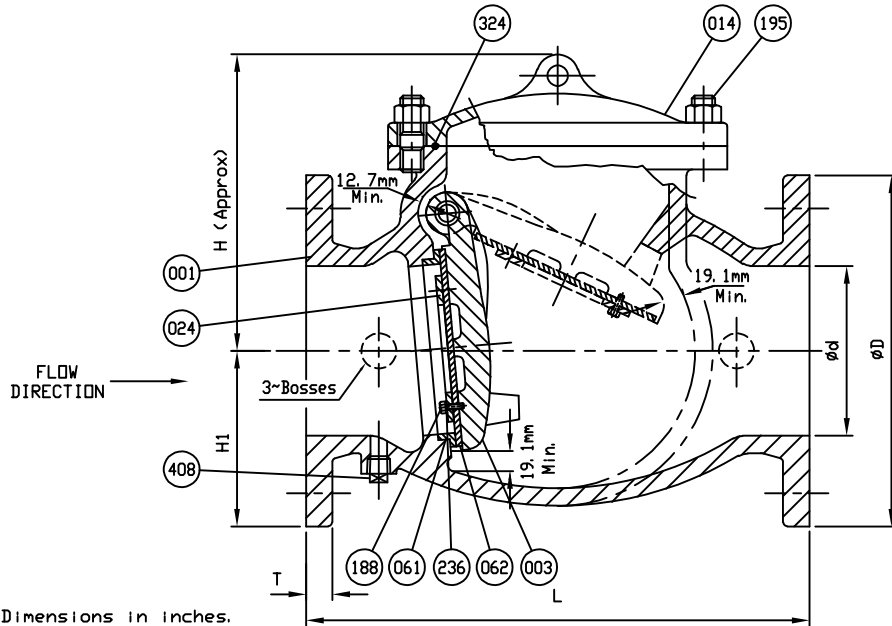

Dimensions in inches.

SIZE Ød in. mm.	L	ANSI B16.1 CL. 125					H	H1	Plug size	WEIGHT	
		ØD	ØC	Øh	n	T				lbs	kg
2 (50)	8±1/16	6	4 3/4	3/4	4	5/8	5 15/16	3	1/2	29	13
2 1/2 (65)	8 1/2±1/16	7	5 1/2	3/4	4	1 1/16	6 9/16	3 1/2	1/2	40	18
3 (80)	9 1/2±1/16	7 1/2	6	3/4	4	3/4	7 3/8	3 3/4	1/2	51	23
4 (100)	11 1/2±1/16	9	7 1/2	3/4	8	15/16	8 1/16	4 1/2	1/2	75	34
6 (150)	14±1/16	11	9 1/2	7/8	8	1	10 5/8	5 1/2	3/4	192	87
8 (200)	19 1/2±1/16	13 1/2	11 3/4	7/8	8	1 1/8	12 3/8	6 3/4	3/4	274	124
10 (250)	24 1/2±1/16	16	14 1/4	1	12	1 3/16	14 1 1/16	8	1	437	198
12 (300)	27 1/2±1/8	19	17	1	12	1 1/4	17 1/16	9 1/2	1	657	298

NO.	PARTS	MATERIAL	ASTM. DESIGNATION.	Q'TY
408	Plug (B)	Stainless Steel	A 276 Type 304	1
329	O-Ring	Rubber (Buna N) or Rubber (EPDM)	D 2000 BK 7014 or D 2000 CA 7014	1
324	Cover Gasket	Rubber (Buna N) or Rubber (EPDM)	D 2000 BK 707 or D 2000 CA 707	1
236	Spring Washer	Stainless Steel	A 276 Type 304	1 set
195	Cover Stud & Nut	Zinc Coated Steel	F3125 Grade A325 Type 1	1 set
188	Disc Seat Bolt	Stainless Steel	A 276 Type 304	1 set
166	Plug (A)	Stainless Steel	A 276 Type 304	1
159	Hinge Pin	Stainless Steel	A 276 Type 304	1
079	Body Bushing	Bronze	B 62	2
078	Disc Bushing	Bronze	B 62	1
062	Disc Seat Ring	Rubber (Buna N) or Rubber (EPDM)	D 2000 BK 7014 or D 2000 CA 7014	1
061	Body Seat Ring	Bronze	B 62	1
024	Seat Holder	Ductile Iron	A 536 Gr. 65-45-12	1
014	Cover	Ductile Iron	A 536 Gr. 65-45-12	1
003	Disc	Ductile Iron	A 536 Gr. 65-45-12	1
001	Body	Ductile Iron	A 536 Gr. 65-45-12	1
NO.	PARTS	MATERIAL	ASTM. DESIGNATION.	Q'TY

MATERIAL LIST

HYDRD SHELL	700	PSI.
HYDRD VALVE SEAT	700	PSI.
TEST PRESSURE		
WORKING PRESSURE	350	PSI.



SCALE	DR.	DATE	REF. DWG.
N.T.S.	J.RAMIREZ	8/15/17	USA2249A
TITLE			
UL/FM SWING CHECK VALVE (UL 312 LISTED & FM 1210 APPROVED) SIZE 2" (50)-12" (300)			
TYPE:	DWG NO.	REV.	
A2122B13	M50110	4	