

No.	DESCRIPTION	MATERIAL
1	SPUD	LEAD FREE BRASS ALLOY ASTM B584
2	COPPER GASKET	COPPER ASTM B152 ALLOY C11000
3	PJ GASKET	EPDM D2000
4	PJ WASHER	POLYPROPYLENE
5	PJ CPLG NUT	CAST BRASS ALLOY ASTM B584

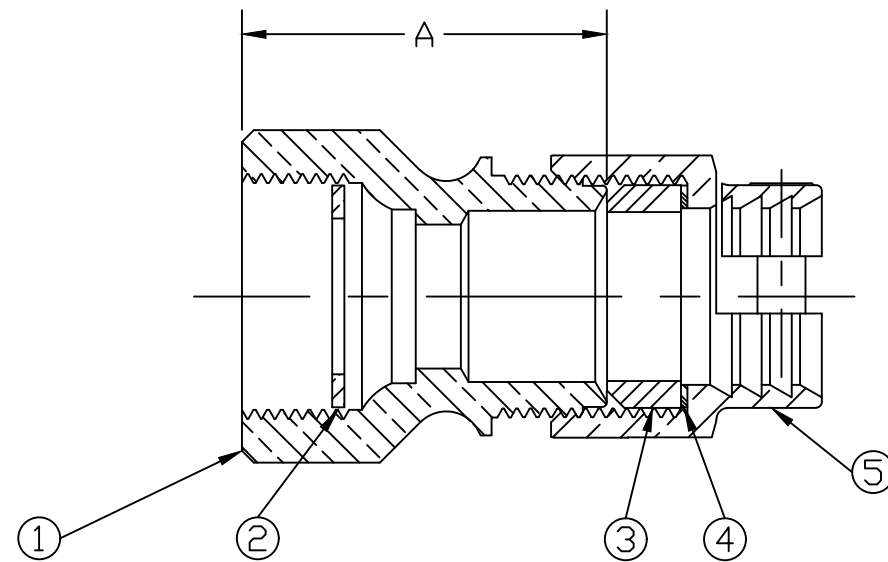

SIZE	A
3/4	1.90
3/4x1	2.32
1	2.52
1x3/4	2.06
1-1/4x1	2.84
1-1/2	2.81
2	3.19

MEETS ALL REQUIREMENTS OF AWWA C800  
 ALL WETTED PARTS ARE LEAD FREE BRASS ALLOY C89833/C87850  
 ALL NON WETTED PARTS ARE BRASS ALLOY C83600/C87850

DWG NUMBER  
P15071N

TITLE TO AND OWNERSHIP OF THIS ENGINEERING  
 DATA REMAINS IN Mueller Co. NO USE IS TO BE  
 MADE OF THIS DATA EXCEPT AS SPECIFICALLY  
 AUTHORIZED BY Mueller Co. ASSENT ON THE PART  
 OF THE RECIPIENT TO THESE CONDITIONS IS PRESUMED

DRFTR	RWB	4/15/15	<b>MUELLER</b>	
CHKR				
ENGR			UNLESS OTHERWISE NOTED SURFACE PREPARATION: BREAK CORNER(S) ---- .000 SURFACE FINISH -- XX RMS	THIRD ANGLE PROJECTION
MGR				TOLERANCE(S): LINEAR ----- ± .000 ANGULAR ----- ± 0°00'
BY		DATE		SCALE
STK No:				FULL
MAT'L:				
DESCR.		CORPORATION STOP COUPLING ("CS" COUPLING x PJ CTS)		DWG NUMBER P15071N