

ITEM NO	PART NUMBER	QTY	DESCRIPTION	MATERIAL
1	282925	1	18" DIA CAST IRON SIDE LOCKING LID (SOLD SEPARATELY)	CAST IRON ASTM A126 CLASS B
2	700098-1	1	CAST IRON FRAME (PURCHASED SEPARATELY)	CAST IRON ASTM A48 CLASS 25A
3	700127-2730	1	27" X 60" SHELL	SDR-51 PVC PIPE ASTM D2241 GRADE 1120

NOTE: FRAME AND LID ORDERED SEPARATELY

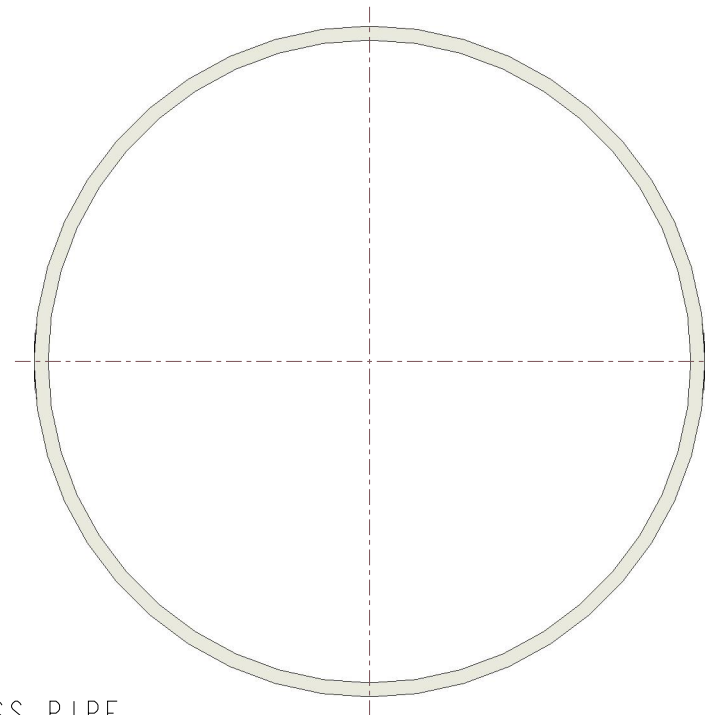
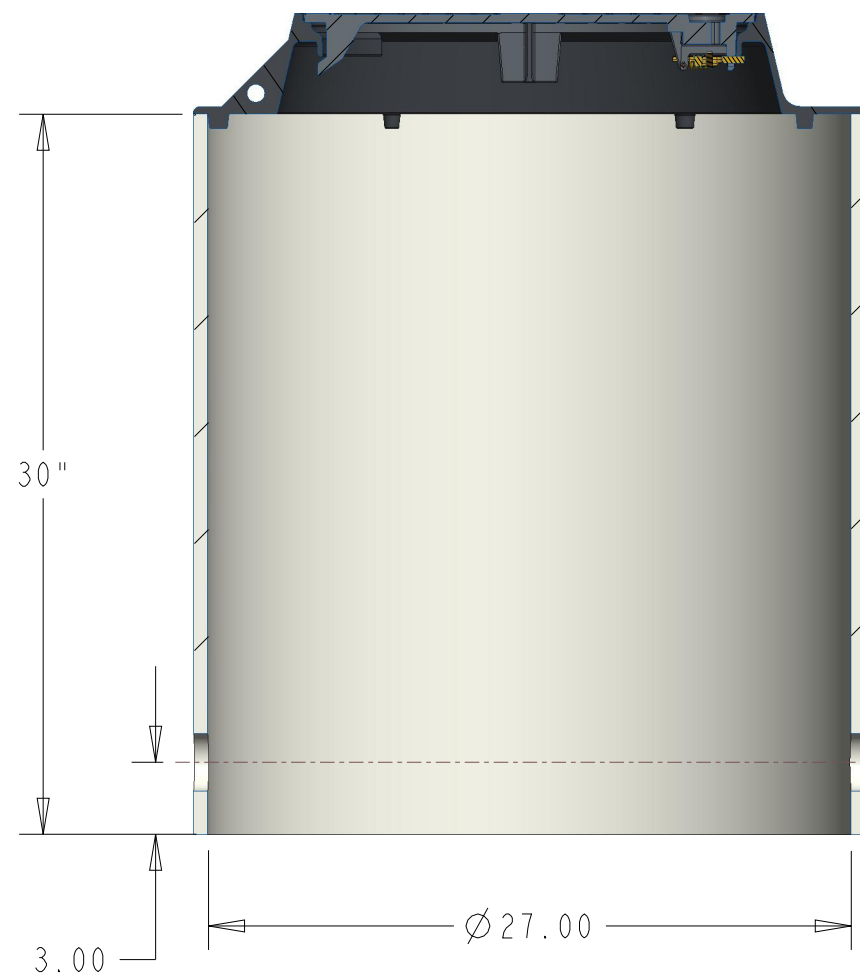

INTERPRET THIS DRAWING IN ACCORDANCE WITH ASME Y14.5 2018		NAME	DATE	THIRD ANGLE PROJECTION	
UNLESS OTHERWISE SPECIFIED DIMENSIONS ARE IN INCHES. MACHINING TOLERANCES:		DRAWN BY	AOS	Jun-03-24	
X	±1	D.E. APPR.			TITLE: SHELL ONLY 27" DIA X 30" DEPTH
.XX	±.015	M.E. APPR.			
.XXX	±.005	Q.A. APPR.			
ANGULAR CORNER BREAK FINISH	±1° .015/.025 125 µin. RA	DO NOT SCALE DRAWING			SIZE
		○ = CRITICAL () = REFERENCE			B
MATERIAL:		DWG. NUMBER			REV
STK NUMBER:		SO2730			A
REF.NO.		SCALE: 0.110			WT:
		SHEET 1 OF 1			

REVISIONS					
REV	ECR	DESCRIPTION	DRAWN BY	DATE	APPROVED
A		DRAWING CREATED	AOS	6/03/24	

TITLE TO AND OWNERSHIP OF THIS ENGINEERING DATA REMAINS IN Mueller Co. ASSENT ON THE PART OF THE RECIPIENT TO THESE CONDITIONS IS PRESUMED.